**Geometrical product specifications
(GPS) — Dimensional tolerancing —**

**Part 1:
Linear sizes**

*Spécification géométrique des produits (GPS) — Tolérancement
dimensionnel —*

Partie 1: Tailles linéaires





COPYRIGHT PROTECTED DOCUMENT

© ISO 2016, Published in Switzerland

All rights reserved. Unless otherwise specified, no part of this publication may be reproduced or utilized otherwise in any form or by any means, electronic or mechanical, including photocopying, or posting on the internet or an intranet, without prior written permission. Permission can be requested from either ISO at the address below or ISO's member body in the country of the requester.

ISO copyright office
Ch. de Blandonnet 8 • CP 401
CH-1214 Vernier, Geneva, Switzerland
Tel. +41 22 749 01 11
Fax +41 22 749 09 47
copyright@iso.org
www.iso.org

Contents

Page

Foreword	iv
Introduction	v
1 Scope	1
2 Normative references	2
3 Terms and definitions	2
4 Specification modifiers and symbols	16
5 Default specification operator for size	19
5.1 General.....	19
5.2 ISO default specification operator for size.....	20
5.3 Drawing-specific default specification operator for size.....	21
6 Drawing indication for special specification operators for size	22
6.1 Basic specification.....	22
6.1.1 General.....	22
6.1.2 Rules to indicate a basic GPS specification.....	22
6.1.3 Rules to indicate basic dimensional specification with modifiers.....	23
6.2 Indication of special specification operators.....	24
6.2.1 One specification operator for both limits (upper and lower) of a size characteristic.....	24
6.2.2 Different specification operator for upper limit of size and lower limit of size.....	27
6.2.3 More than one dimensional specification applied to a linear feature of size.....	29
6.3 Tolerancing of fits on assembly drawings.....	30
7 Indication of the toleranced feature on which the size characteristic is defined	31
7.1 Complete toleranced linear feature of size.....	31
7.2 Specific fixed restricted portion of the feature of size.....	31
7.3 Any restricted portion of the feature of size of a specified length.....	32
7.4 Any cross section or any longitudinal section of a linear feature of size.....	33
7.5 Size characteristic in a specific cross section of a feature of size.....	35
7.6 Requirement applied individually for more than one feature of size.....	37
7.7 Requirement applied for more than one feature considered as one feature of size.....	38
7.8 Flexible/non-rigid parts.....	38
8 Complementary indication	39
Annex A (normative) Proportions and dimensions of graphical symbols	40
Annex B (informative) Overview diagram for linear size	42
Annex C (informative) Data handling with rank-order modifiers	43
Annex D (normative) Size characteristics	45
Annex E (normative) Graphical rules to locate and dimension the dimensional specification elements	50
Annex F (informative) Relation to the GPS matrix model	54
Bibliography	56

Foreword

ISO (the International Organization for Standardization) is a worldwide federation of national standards bodies (ISO member bodies). The work of preparing International Standards is normally carried out through ISO technical committees. Each member body interested in a subject for which a technical committee has been established has the right to be represented on that committee. International organizations, governmental and non-governmental, in liaison with ISO, also take part in the work. ISO collaborates closely with the International Electrotechnical Commission (IEC) on all matters of electrotechnical standardization.

The procedures used to develop this document and those intended for its further maintenance are described in the ISO/IEC Directives, Part 1. In particular the different approval criteria needed for the different types of ISO documents should be noted. This document was drafted in accordance with the editorial rules of the ISO/IEC Directives, Part 2 (see www.iso.org/directives).

Attention is drawn to the possibility that some of the elements of this document may be the subject of patent rights. ISO shall not be held responsible for identifying any or all such patent rights. Details of any patent rights identified during the development of the document will be in the Introduction and/or on the ISO list of patent declarations received (see www.iso.org/patents).

Any trade name used in this document is information given for the convenience of users and does not constitute an endorsement.

For an explanation on the meaning of ISO specific terms and expressions related to conformity assessment, as well as information about ISO's adherence to the WTO principles in the Technical Barriers to Trade (TBT) see the following URL: [Foreword - Supplementary information](#)

The committee responsible for this document is ISO/TC 213, *Dimensional and geometrical product specification and verification*.

This second edition cancels and replaces the first edition (ISO 14405-1:2010), which has been technically revised.

The main changes from the previous edition are:

- [Clauses 1](#) and [3](#), [5.3](#), [6.1](#), [6.2](#), [7.3](#), [7.8](#), [Tables 1](#) and [2](#), and the figures have been technically revised;
- [Clause 8](#) and [Annexes D](#) and [E](#) have been added.

ISO 14405 consists of the following parts, under the general title *Geometrical product specifications (GPS) — Dimensional tolerancing*:

- *Part 1: Linear sizes*
- *Part 2: Dimensions other than linear sizes*
- *Part 3: Angular sizes*

Introduction

This part of ISO 14405 is a geometrical product specification (GPS) standard and is to be regarded as a general GPS standard (see ISO 14638). It influences chain links A to C of the chain of standards on size.

The ISO GPS matrix model given in ISO 14638 gives an overview of the ISO GPS system of which this part of ISO 14405 is a part. The fundamental rules of ISO GPS given in ISO 8015 apply to this part of ISO 14405 and the default decision rules given in ISO 14253-1 apply to the specifications made in accordance with this part of ISO 14405, unless otherwise indicated.

For more detailed information of the relation of this part of ISO 14405 to other standards and the GPS matrix model, see [Annex F](#).

Produced workpieces exhibit deviations from the ideal geometric form. The real value of the dimension of a feature of size is dependent on the form deviations and on the specific type of size applied.

The type of size to be applied to a feature of size depends on the function of the workpiece.

The type of size can be indicated on the drawing by a specification modifier for controlling the feature definition.

Geometrical product specifications (GPS) — Dimensional tolerancing —

Part 1: Linear sizes

IMPORTANT — The illustrations included in this part of ISO 14405 are intended to illustrate the text and/or to provide examples of the related technical drawing specification. These illustrations are not fully dimensioned and toleranced showing only the relevant general principles. As a consequence, the illustrations are not a representation of a complete workpiece and are not of a quality that is required for use in industry (in terms of full conformity with the standards prepared by ISO/TC 10 and ISO/TC 213) and as such, are not suitable for projection for teaching purposes

1 Scope

This part of ISO 14405 establishes the default specification operator (see ISO 17450-2) for linear size and defines a number of special specification operators for linear size for features of size, e.g. “cylinder”, “sphere”, “torus”,¹⁾ “circle”, “two parallel opposite planes”, or “two parallel opposite straight lines”.

It also defines the specification modifiers and the drawing indications for these linear sizes.

This part of ISO 14405 covers the following linear sizes:

- a) local size:
 - two-point size;
 - spherical size;
 - section size;
 - portion size;
- b) global size:
 - direct global linear size:
 - least-squares size;
 - maximum inscribed size;
 - minimum circumscribed size;
 - minimax size;
 - indirect global linear size;
- c) calculated size:
 - circumference diameter;
 - area diameter;
 - volume diameter;

1) A torus is a feature of size when its directrix diameter is fixed.

ISO 14405-1:2016(E)

- d) rank-order size:
- maximum size;
 - minimum size;
 - average size;
 - median size;
 - mid-range size;
 - range of sizes;
 - standard deviation of sizes.

This part of ISO 14405 defines tolerances of linear sizes for the following:

- a + and/or – limit deviation (e.g. 0/–0,019) (see [Figure 11](#));
- an upper limit of size (ULS) and/or lower limit of size (LLS) (e.g. 15,2 max., 12 min., or 30,2/30,181) (see [Figure 13](#));
- an ISO tolerance class code in accordance with ISO 286-1 (e.g. 10 h6) (see [Figure 12](#));

with or without modifiers (see [Tables 1](#) and [2](#)).

This part of ISO 14405 provides a set of tools to express several types of size characteristic. It does not present any information on the relationship between a function or a use and a size characteristic.

2 Normative references

The following documents, in whole or in part, are normatively referenced in this document and are indispensable for its application. For dated references, only the edition cited applies. For undated references, the latest edition of the referenced document (including any amendments) applies.

ISO 286-1, *Geometrical product specifications (GPS) — ISO code system for tolerances on linear sizes — Part 1: Basis of tolerances, deviations and fits*

ISO 8015, *Geometrical product specifications (GPS) — Fundamentals — Concepts, principles and rules*

ISO 17450-1, *Geometrical product specifications (GPS) — General concepts — Part 1: Model for geometrical specification and verification*

ISO 17450-2:2012, *Geometrical product specifications (GPS) — General concepts — Part 2: Basic tenets, specifications, operators, uncertainties and ambiguities*

ISO 17450-3, *Geometrical product specifications (GPS) — General concepts — Part 3: Toleranced features*

ISO 81714-1, *Design of graphical symbols for use in the technical documentation of products — Part 1: Basic rules*

3 Terms and definitions

For the purposes of this document, the terms and definitions given in ISO 286-1, ISO 8015, ISO 17450-1, ISO 17450-2, ISO 17450-3, and the following apply.

**3.1
feature of size**

feature of linear size or feature of angular size

Note 1 to entry: Feature of linear size and feature of angular size are synonyms of linear feature of size and angular feature of size, respectively.

Note 2 to entry: [Figures 1](#) and [2](#) illustrate a linear feature of size, type cylinder, or two parallel opposite planes.

Note 3 to entry: This part of ISO 14405 only deals with features of linear size which can be a cylinder, a sphere, two parallel opposite planes, a circle (intersection of a revolute surface and a plane perpendicular to the axis of the associated surface), two parallel opposite straight lines (the intersection of a cylindrical surface and a plane containing the associated axis of the cylindrical surface or a prismatic surface and a plane perpendicular to the associated median plane of the prismatic surface), and two opposite circles (the intersection of a pair of coaxial revolute tube surfaces and a plane perpendicular to the axis of one of the revolute surfaces), i.e. the wall thickness of a tube.

Note 4 to entry: Two opposite straight lines can be symmetrically established from the associated axis for a cylindrical surface or a plane perpendicular to the plane of a prismatic surface. Two opposite circles can be established from the intersection of a pair of coaxial revolute surface and a plane perpendicular to the axis of one the revolute surfaces or intersection of a collection of two single surfaces and a section feature which is a cylinder.

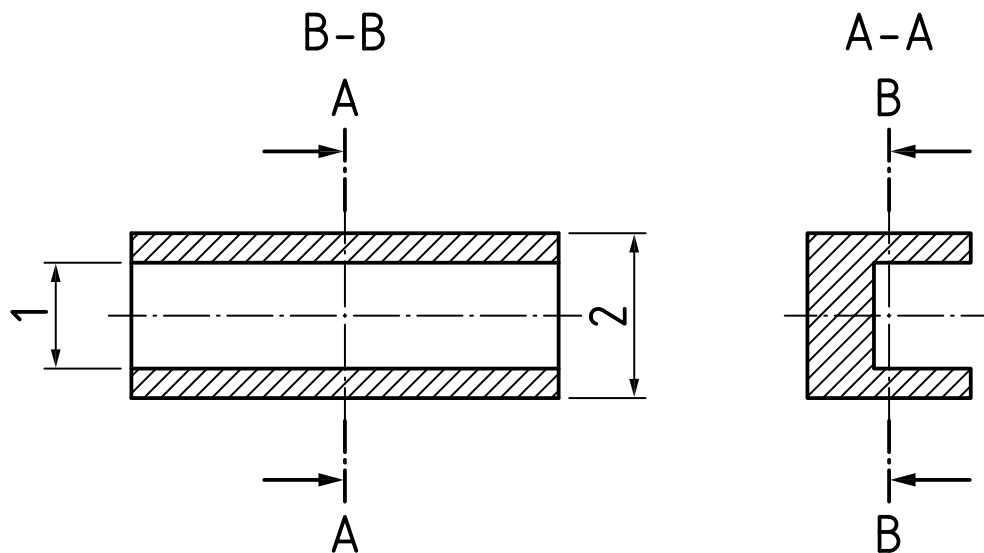

a) Nominal features of linear size (internal and external)

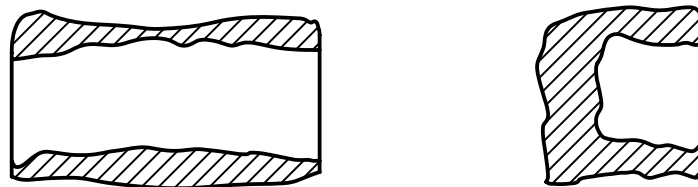

b) Extracted feature

Key

- 1 size of internal linear feature of size
- 2 size of external linear feature of size

Figure 1 — Example of a linear feature of size consisting of two opposite planes

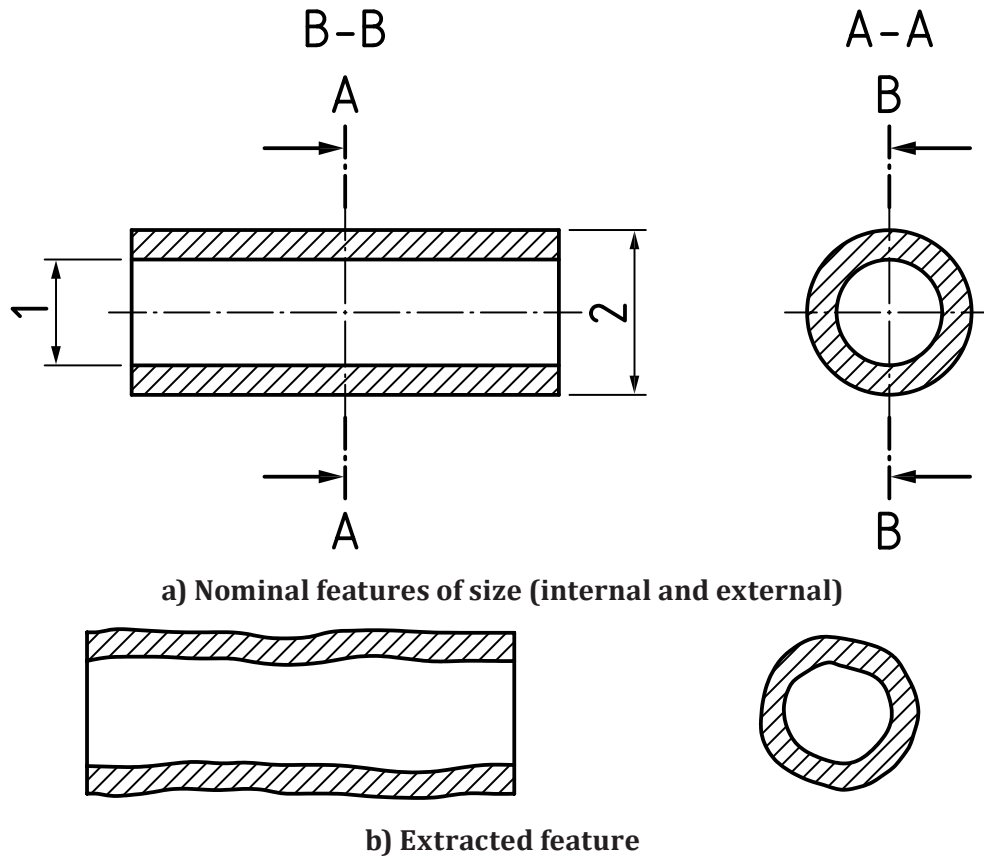

Key

- 1 size of internal linear feature of size
- 2 size of external linear feature of size

Figure 2 — Example of a linear feature of size consisting of a cylinder

[SOURCE: ISO 17450-1:2011, 3.3.1.5]

3.2
upper limit of size
upper limit of size characteristic
ULS

largest permissible value for a *size characteristic* (3.5)

3.3
lower limit of size
lower limit of size characteristic
LLS

smallest permissible value for a *size characteristic* (3.5)

3.4
size

dimensional parameter considered variable for a *feature of size* (3.1) that can be defined on a nominal feature or on an associated feature

Note 1 to entry: In this part of ISO 14405, the size is linear, e.g. the diameter of a cylinder or the distance between two parallel opposite planes, two opposing lines, and two concentric circles. Depending on the type of linear feature of size, the terms “diameter”, “width”, and “thickness” are synonyms for size.

Note 2 to entry: A size is angular (e.g. angle of a cone) or linear (e.g. diameter of a cylinder). This part of ISO 14405 only deals with linear size.

3.5**size characteristic**

characteristic relative to a *size* (3.4) and defined from an extracted integral feature

Note 1 to entry: See [Figure B.1](#).

Note 2 to entry: A size can be evaluated by more than one size characteristic (e.g. the two-point diameter or the diameter of the associated feature taken on the extracted feature).

3.6**local size**

local linear size

local size characteristic

local linear size characteristic

size characteristic (3.5) having by definition a non-unique result of evaluation along and/or around a *feature of size* (3.1)

Note 1 to entry: For a given feature, an infinity of local sizes exists.

Note 2 to entry: A two-point size on two opposite planes can be called a “two-point thickness” or a “two-point width”.

Note 3 to entry: In [Figure 3](#), examples of local size are shown. These examples do not take into account the *rank-order size* (3.7.2.2).

Note 4 to entry: Elementary types of size characteristic are defined in [Annex D](#).

3.6.1**two-point size**

<local size> distance between two opposite points on a extracted integral linear feature of size

Note 1 to entry: A two-point size on a cylinder can be called a “two-point diameter”.

Note 2 to entry: A two-point size on two opposite planes can be called a “two-point distance”.

Note 3 to entry: The method establishing a two-point size from any kind of features of size is given in ISO 17450–3.

3.6.2**section size**

global size (3.7) for a given cross section of the extracted integral feature

Note 1 to entry: A section size is a *local size* (3.6) for the complete toleranced *feature of size* (3.1).

Note 2 to entry: The cross section is defined with the same criterion as the one taken to define the *direct global size* (3.7.1).

Note 3 to entry: On an extracted feature which is a cylinder, it is possible to define an infinite number of cross sections in which the diameter of the associated circle can be defined (with a specific association criterion). This is a section size.

3.6.3**portion size**

global size (3.7) for a given portion of the extracted feature

Note 1 to entry: A portion size is a *local size* (3.6) for the complete toleranced *feature of size* (3.1).

3.6.4**spherical size**

<local size> diameter of the maximum inscribed sphere

Note 1 to entry: The maximum inscribed sphere is used when defining the spherical size of both internal and external feature of size.

Note 2 to entry: See [Figure 3 c](#)).

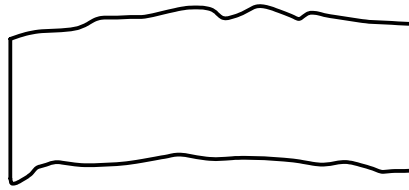

a) Extracted feature under consideration which could be either an internal or external feature and either a cylinder or two opposite planes

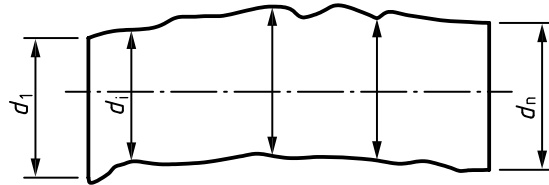

b) Two-point sizes (see ISO 17450-3)

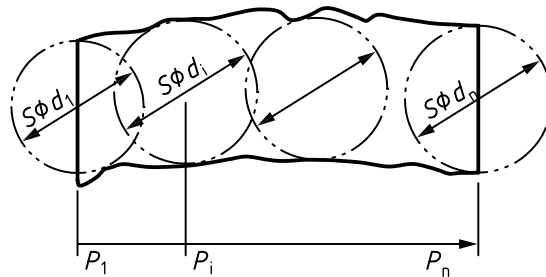

c) Spherical sizes

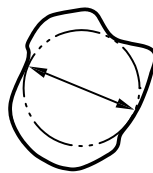

d) Section size obtained from a direct global size with maximum inscribed criterion (other criteria are possible)

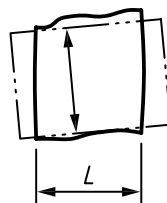

e) Portion size from a direct global size with maximum inscribed criterion (other criteria are possible)

Key

- d size [in Figure 3 b)]
- L considered length of the portion of the cylinder
- P position
- $Sød$ diameter of the maximum inscribed sphere

NOTE 1 The section size of Figure 3 d) in each cross section is given by the diameter of the maximum inscribed circle defined in that cross section.

NOTE 2 Only a portion of the extracted feature of length, L , is considered in Figure 3 e).

Figure 3 — Examples of local size

3.7**global size**

global linear size

global size characteristic

global linear size characteristic

size characteristic (3.5) having by definition a unique value along and around a tolerated *feature of size* (3.1)

3.7.1**direct global size**

direct global linear size

direct global size characteristic

direct global linear size characteristic

global size (3.7) equals to the size of an associated integral feature which is of the same geometrical type as the *feature of size* (3.1) and which is established without constraint of size, orientation, or location

Note 1 to entry: The different direct global linear sizes are given in [Figure 4](#).

Note 2 to entry: Different criteria may be used for this operation of association and different results are obtained depending on the criterion chosen. The association criteria described in this part of ISO 14405 are total least-squares, maximum inscribed, minimum circumscribed, and minimax criteria.

Note 3 to entry: The associated integral feature (established from the extracted integral feature) has the same ideal shape as the feature of size. Its size is considered variable.

3.7.1.1**least-squares size**

direct global size (3.7.1) for which an associated integral feature is established from the extracted integral feature(s) with the total least-squares criterion

Note 1 to entry: In this part of ISO 14405, “total least-squares” is referred to only as “least-squares”. It minimizes the sum of the square of distances existing between the associated integral feature and the extracted integral feature.

3.7.1.2**maximum inscribed size**

direct global size (3.7.1) for which an associated integral feature is established from the extracted integral feature(s) with the maximum inscribed criterion

Note 1 to entry: In the case of an internal linear feature of size, the maximum inscribed size was previously called “mating size for an internal feature”. It maximizes the size of the associated integral feature which can be inscribed in the extracted integral feature (with constraint of contact between the extracted integral feature and the associated integral feature).

3.7.1.3**minimum circumscribed size**

direct global size (3.7.1) for which an associated integral feature is established from the extracted integral feature(s) with the minimum circumscribed criterion

Note 1 to entry: In the case of an external linear feature of size, the minimum circumscribed size was previously called “mating size for an external feature”. It minimizes the size of the associated feature which can be circumscribed to the extracted integral feature (with constraint of contact between the extracted integral feature and the associated integral feature).

3.7.1.4

minimax size

Chebyshev size

direct global size (3.7.1) for which an associated integral feature is established from the extracted integral feature(s) with the minimax criterion

Note 1 to entry: The minimax criterion without constraint of inside or outside material gives the medium feature of the minimum zone including the extracted integral feature. It minimizes the maximum value of the set of distances between the points of the extracted integral feature and the associated integral feature without material constraint.

3.7.2

indirect global size

indirect global linear size

indirect global size characteristic

indirect global linear size characteristic

rank-order size (3.7.2.2) or *global calculated size* (3.7.2.1)

Note 1 to entry: An indirect global size can be, for example, an average of a set of two-point size values taken on the extracted cylindrical surface.

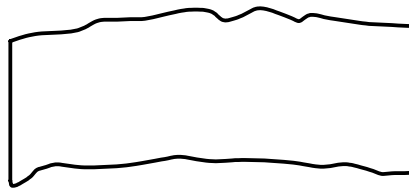

a) Extracted feature under consideration which could be either an internal or external feature and either a cylinder or two opposite planes

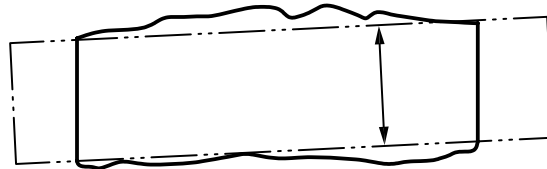

b) Maximum inscribed size

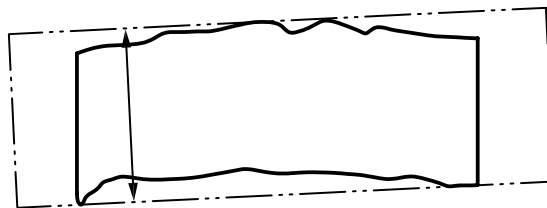

c) Minimum circumscribed size

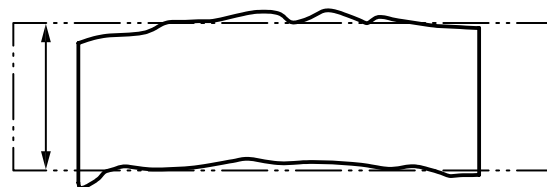

d) Least-squares size

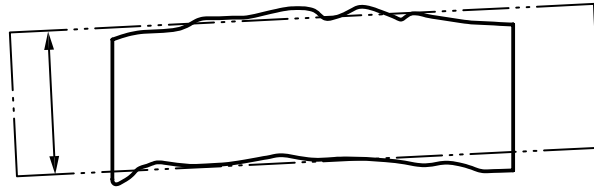

e) Minimax size

Figure 4 — Illustration of direct global sizes

3.7.2.1

calculated size

size (3.4) obtained by using a mathematical formula that relates the intrinsic characteristic of a feature to one or several other dimensions of the same feature

Note 1 to entry: The calculated size can be a *local size* (3.6) or a *global size* (3.7).

3.7.2.1.1

circumference diameter

<of an extracted cylinder> *calculated size* (3.7.2.1) giving the diameter, d , obtained from the following formula:

$$d = \frac{C}{\pi}$$

where C is the length of the integral extracted line in a cross section normal to the axis of the least-squares associated cylinder

Note 1 to entry: See Figure 5.

Note 2 to entry: The circumference diameter is defined in a cross section.

Note 3 to entry: Several criteria can be used for the operation of association to orient the cross section and different results are obtained according to the chosen criterion. The default criterion is the least-squares associated cylinder of the feature (see ISO 17450-3).

Note 4 to entry: In cases where the feature is non-convex, the circumference diameter can be larger than the minimum circumscribed diameter.

Note 5 to entry: The circumference diameter depends on the filtration criteria used.

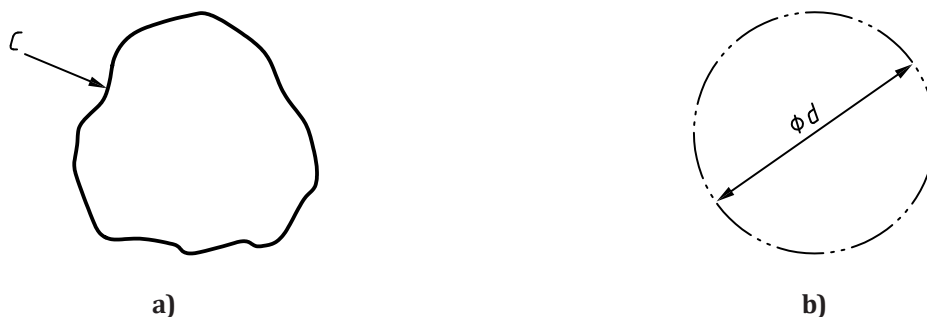

Key

C length of the outline (extracted line)

d circumference diameter, equal to C divided by π

Figure 5 — Example of circumference diameter

3.7.2.1.2
area diameter

<of an extracted cylinder> *calculated size* (3.7.2.1) giving the diameter, d , obtained from the following formula:

$$d = \sqrt{\frac{4A}{\pi}}$$

where A is the area limited by the integral extracted line of a cross section normal to the axis of the least-squares associated cylinder

Note 1 to entry: See [Figure 6](#).

Note 2 to entry: The area diameter is defined in a cross section.

Note 3 to entry: Several criteria may be used for the operation of association to orient the cross section and different results are obtained according to the chosen criterion. The default criterion is the least-squares associated cylinder of the feature (see ISO 17450-3).



Key

- A area inside outline of the extracted line
- d area diameter, calculated from A

Figure 6 — Example of area diameter

3.7.2.1.3
volume diameter

<of an extracted cylinder> *calculated size* (3.7.2.1) giving the diameter, d , obtained from the following formula:

$$d = \sqrt{\frac{4V}{\pi \times L}}$$

where

- V is the volume limited by the integral extracted cylinder;
- L is the height of the cylinder taken between two parallel planes perpendicular to the axis of the least-squares associated cylinder with the maximum distance between them and containing a complete section of the feature

Note 1 to entry: See [Figure 7](#).

Note 2 to entry: Several criteria may be used for the operation of association to orient the cross sections intersecting the extracted cylinder and defining L . Different results are obtained according to the chosen criterion. The default criterion is the least-squares associated cylinder of the feature (see ISO 17450-3).

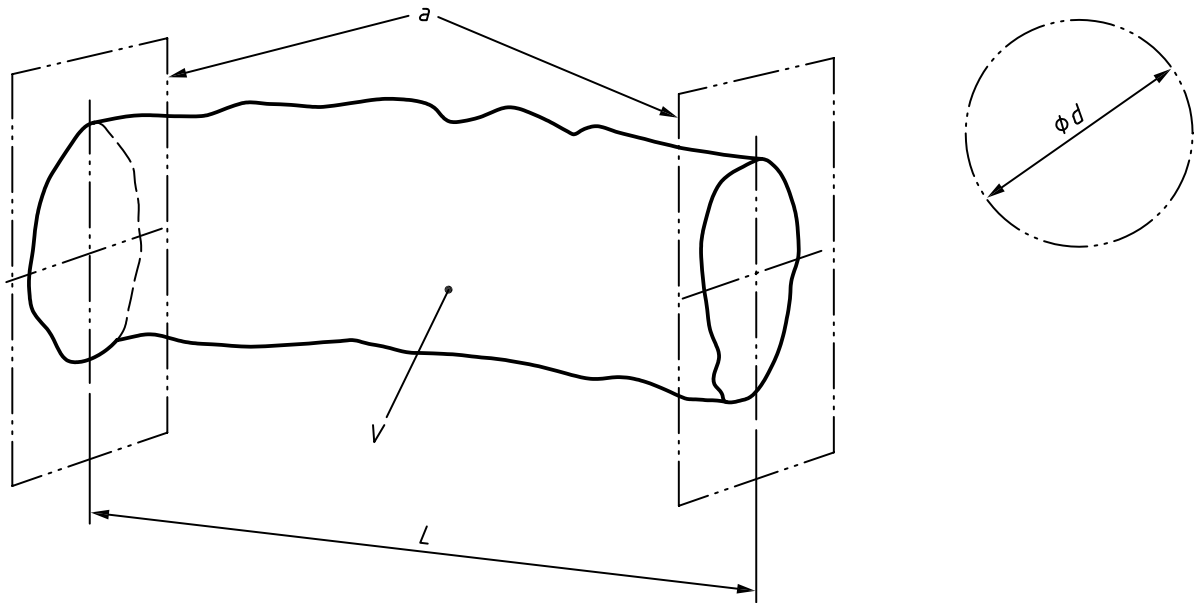
**Key**

V volume of the extracted feature

L length of the cylinder

d volume diameter, calculated from V and L

^a Two parallel planes perpendicular to the axis of the least-squares associated cylinder with the maximum distance between them and containing a complete section of the feature.

Figure 7 — Example of volume diameter

3.7.2.2**rank-order size**

size characteristic (3.5) defined mathematically from a homogeneous set of *local size* (3.6) values obtained along and/or around the tolerated feature

Note 1 to entry: A rank-order size can be used to define an *indirect global size* (3.7.2) from a *local size* (3.6) (*portion size* (3.6.3), *section size* (3.6.2), *spherical size* (3.6.4), and *two-point size* (3.6.1)).

Note 2 to entry: A rank-order size can be used to define a local size from another local size (for example, to define a rank order section size from a two-point size taken in the section).

Note 3 to entry: The different types of rank-order size defined in this part of ISO 14405 are illustrated in [Figure 8](#).

3.7.2.2.1**maximum size**

rank-order size (3.7.2.2) defined as the maximum of the set of values of a *local size* (3.6) along and/or around the tolerated feature

3.7.2.2.2**minimum size**

rank-order size (3.7.2.2) defined as the minimum of the set of values of a *local size* (3.6) along and/or around the tolerated feature

3.7.2.2.3**average size**

rank-order size (3.7.2.2) defined as the average of the set of values of a *local size* (3.6) along and/or around the tolerated feature

3.7.2.2.4

median size

rank-order size (3.7.2.2) defined as the median value of the set of values of a *local size* (3.6) along and/or around the toleranced feature

Note 1 to entry: The median value allows the population of local size values to be split into two equal portions (50 % above and 50 % below). Depending on the function of repartition of the population, the median size, and the average size can be identical or different.

3.7.2.2.5

mid-range size

rank-order size (3.7.2.2) defined as the mean of the maximum and the minimum of the set of values of a *local size* (3.6) along and/or around the toleranced feature

3.7.2.2.6

range of sizes

rank-order size (3.7.2.2) defined as the difference between the maximum and the minimum of the set of values of a *local size* (3.6) along and/or around the toleranced feature

3.7.2.2.7

standard deviation of sizes

rank-order size (3.7.2.2) defined as the standard deviation of the set of values of a *local size* (3.6) along and/or around the toleranced feature

Note 1 to entry: A standard deviation is sometimes presented as a quadratic sum explaining the second letter of the associated symbol (see [Table 1](#)).

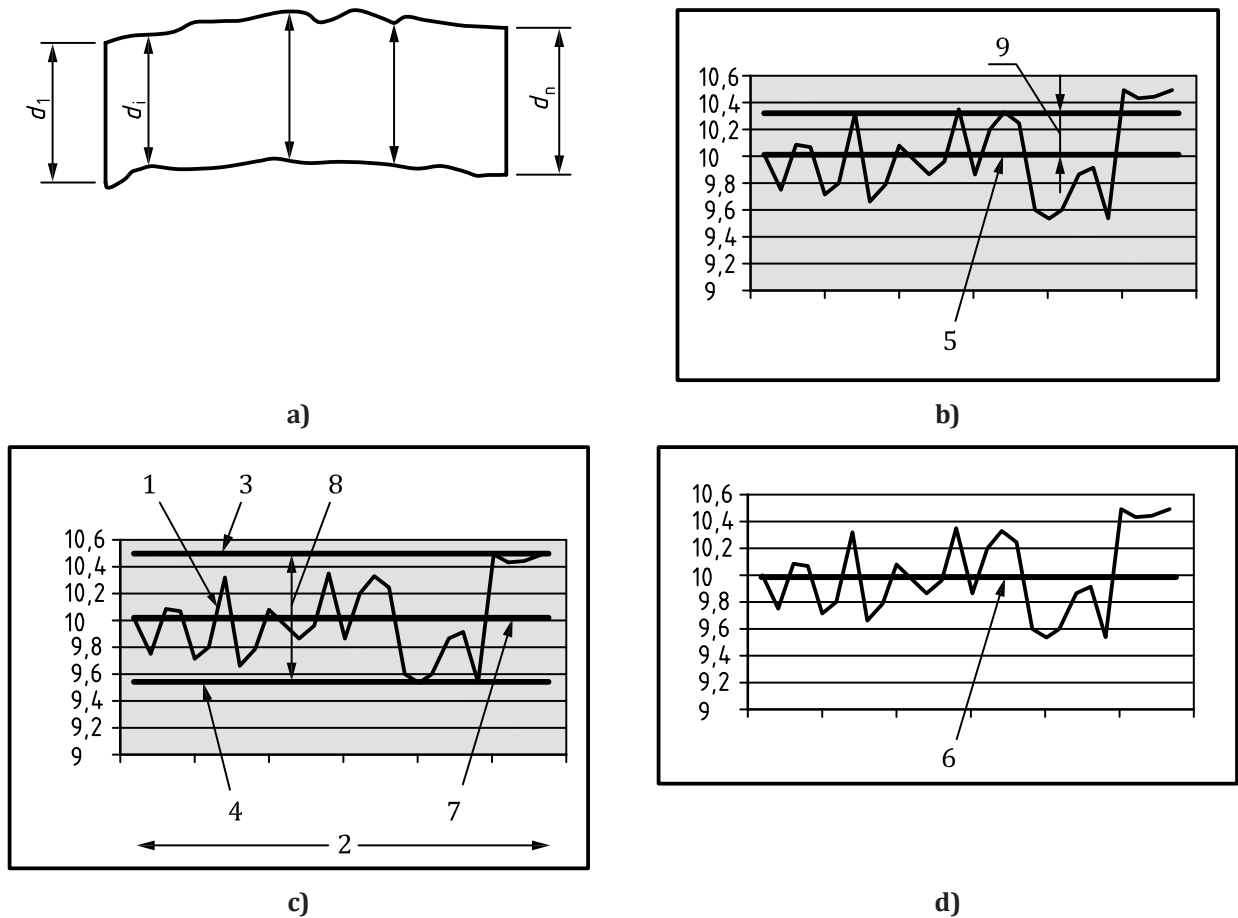

Key

- | | | | |
|---|------------------------------|-------|--|
| 1 | set of values of local sizes | 6 | median size (= 9,969 86) |
| 2 | position along the axis | 7 | mid-range size (= 10,020 345) |
| 3 | maximum size (= 10,497 88) | 8 | size range (= 0,955 07) |
| 4 | minimum size (= 9,542 81) | 9 | standard deviation of sizes (=0,30178) |
| 5 | average size (= 10,011 69) | d_i | values of local size |

Figure 8 — Example of rank-order sizes based on the two-point size

3.8 envelope requirement

combination of the *two-point size* (3.6.1) applied for the least material limit of the size (3.4) and either the *minimum circumscribed size* (3.7.1.3) or the *maximum inscribed size* (3.7.1.2) applied for the maximum material limit of the size

Note 1 to entry: The “envelope requirement” was previously referred to as the “Taylor principle”.

3.8.1 envelope requirement for external features of size

combination of the *two-point size* (3.6.1) applied for the *lower limit of size (LLS)* (3.3) and the *minimum circumscribed size* (3.7.1.3) applied for the *upper limit of size (ULS)* (3.2)

Note 1 to entry: See Figure 9.

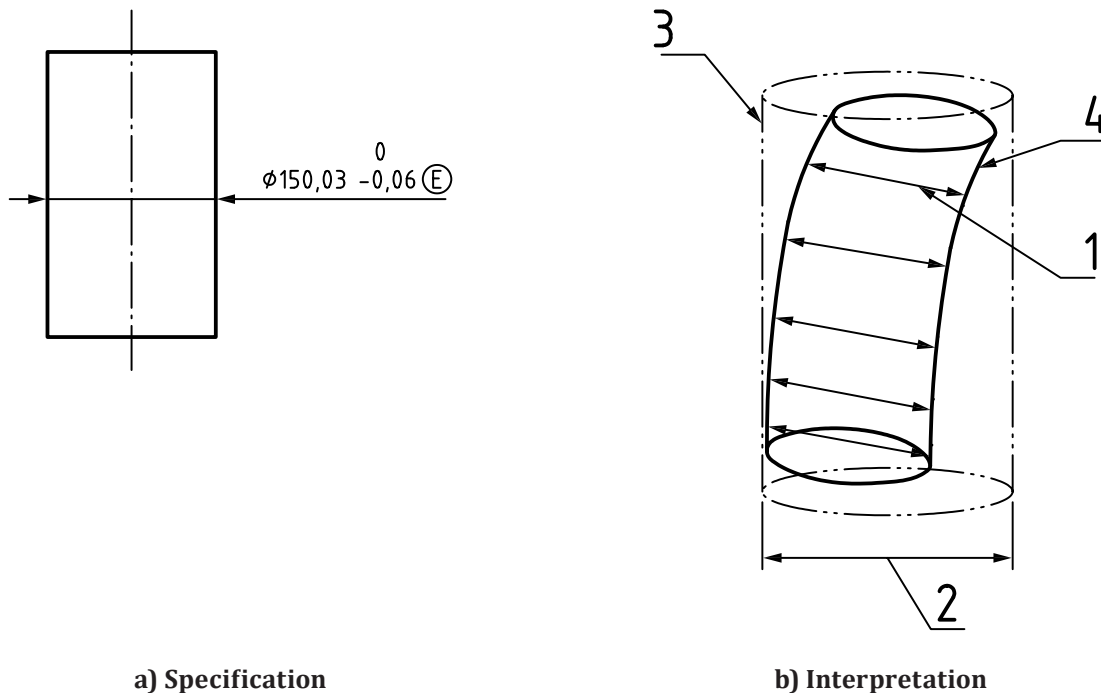

Key

- 1 two-point sizes (required to be larger than or equal to 149,97)
- 2 diameter of envelope cylinder equal to 150,03mm
- 3 envelope cylinder including 4
- 4 extracted integral feature

Figure 9 — Example of envelope requirement for external linear feature of size

3.8.2

envelope requirement for internal features of size

combination of the *two-point size* (3.6.1) applied for the *upper limit of size (ULS)* (3.2) and the *maximum inscribed size* (3.7.1.2) applied for the *lower limit of size (LLS)* (3.3)

Note 1 to entry: See [Figure 10](#).

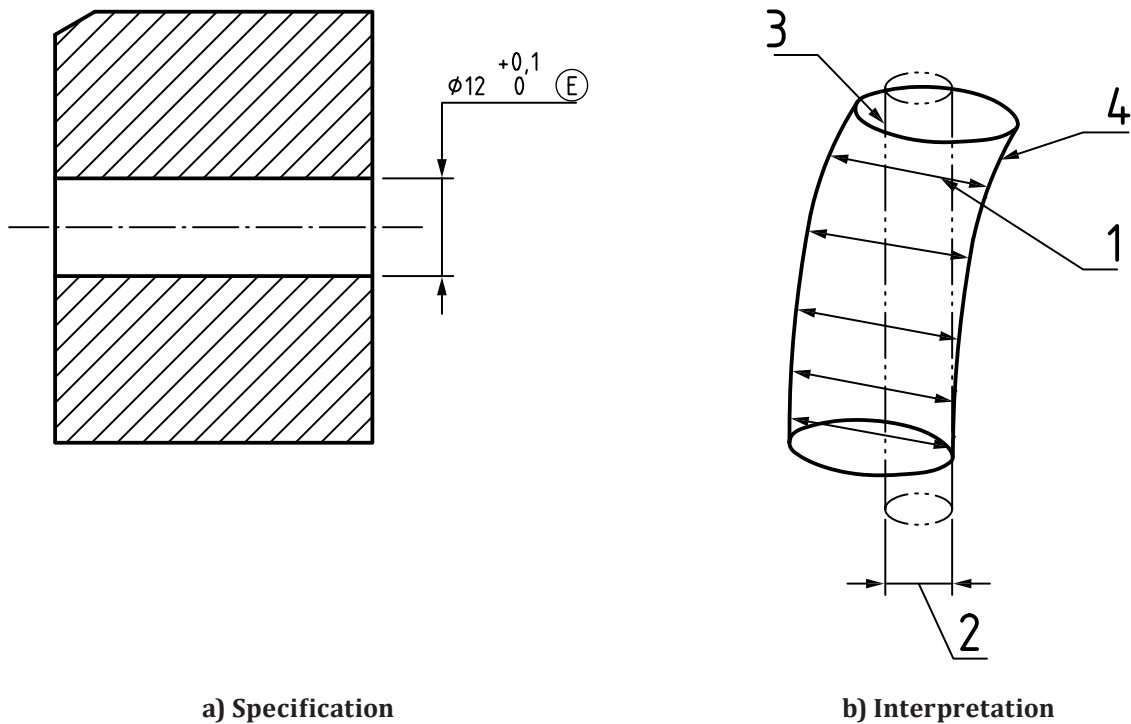

a) Specification

b) Interpretation

Key

- 1 two-point sizes (required to be smaller than or equal to 12,1)
- 2 diameter of envelope cylinder equal to 12 mm
- 3 envelope cylinder included within 4
- 4 extracted integral feature

Figure 10 — Example of envelope requirement for internal linear feature of size

3.9 common toleranced feature of size

several separate single features of size considered as one *feature of size* (3.1) on which a common tolerance is applied

Note 1 to entry: See 7.7 and Figure 33.

3.10 united feature of size

set of two or more single integral features considered as one *feature of size* (3.1)

Note 1 to entry: a united feature of size is a sub-type of united feature. A united feature can be an integral feature which is not a feature of size.

3.11 intersection plane

plane, established from an extracted feature of the workpiece, identifying a line on an extracted surface (integral or median) or a point on an extracted line

3.12 direction feature

feature, established from an extracted feature of the workpiece, identifying the direction of distance used to define a characteristic

Note 1 to entry: This definition is adapted from ISO 1101:2012 to broaden its scope which is limited in ISO 1101 to identify the direction of the width of the tolerance zone.

4 Specification modifiers and symbols

For the purposes of this part of ISO 14405, the specification modifiers (see ISO 17450-2:2012, 3.4.2) and symbols in [Tables 1](#) and [2](#) apply.

To define in a dimensional specification a specific type of size characteristic available for upper and/or lower limit specification, modifiers or symbols shall be used in the sequence as defined in [Table 3](#).

The combination of these modifiers and symbols is described in [Clauses 5](#), [6](#), and [7](#). Rules for the presentation of graphical symbols are given in [Annex A](#).

Details of size characteristics are given in [Annex D](#).









The presentation of indications of size specifications shall follow the rules given in [Annex E](#).

Table 1 — Specification modifiers for linear size

Modifier	Description	Reference
ⓁP	Two-point size	3.6.1
ⓁS	Local size defined by a sphere	3.6.4
ⓁG	Least-squares association criterion	3.7.1.1
ⓁX	Maximum inscribed association criterion	3.7.1.2
ⓁN	Minimum circumscribed association criterion	3.7.1.3
ⓁC	Minimax (Chebyshev) association criteria	3.7.1.4
ⓁC	Circumference diameter (calculated size)	3.7.2.1.1
ⓁA	Area diameter (calculated size)	3.7.2.1.2
ⓁV	Volume diameter (calculated size)	3.7.2.1.3
ⓁX	Maximum size ^a	3.7.2.2.1
ⓁN	Minimum size ^a	3.7.2.2.2
ⓁA	Average size ^a	3.7.2.2.3
ⓁM	Median size ^a	3.7.2.2.4
ⓁD	Mid-range size ^a	3.7.2.2.5
ⓁR	Range of sizes ^a	3.7.2.2.6
ⓁQ	Standard deviation of sizes ^a	3.7.2.2.7

^a Rank-order size can be used as a supplement to calculated portion size or global portion size or local size (see [3.7.2.2](#) and [6.1.3](#)).

Table 2 — Complementary specification modifiers

Description	Symbol	Reference	Example of indication
United feature of size ^b	UF	7.1	UF 3× $\phi 10 \pm 0,1$ (GN)
Envelope requirement	(E)	6.2.2	10 $\pm 0,1$ (E)
Any restricted portion of feature	/Length	7.3	$\phi 10 \pm 0,1$ (GG) / 5
Any cross section	ACS	7.4	$\phi 10 \pm 0,1$ (GX) ACS
Specific fixed cross section	SCS	7.5	10 $\pm 0,1$ (GX) CSC
Any longitudinal section	ALS	7.4	10 $\pm 0,1$ (GX) ALS
More than one feature	Number ×	7.6 7.7	2× 10 $\pm 0,1$ (E)
Common toleranced feature of size	CT	7.7	2× $\phi 10 \pm 0,1$ (E) CT
Free-state condition	(F)	7.8	$\phi 10 \pm 0,1$ (LP) (SA) (F)
Between		7.2 to 7.3	$\phi 10 \pm 0,1$ A  B
Intersection plane ^a		7.4	5 $\pm 0,02$ ALS 
Direction feature ^a		7.4	5 $\pm 0,02$ ALS 
Flagnote		8	10 $\pm 0,1$ 

^a For more information, see ISO 1101.

^b The symbol UF can be used to identify a united feature of size or a united feature which is not a feature of size.

Table 3 — Type and sub-type of size characteristic and associated modifiers

Type of size characteristic	Subtype	Additional definition	Associated modifiers
Local size	Two-point size		(LP)
	Spherical size		(LS)
		With least-squares association criteria	(GG) ACS or (GG) ALS or (GG) SCS
		With maximum inscribed association criteria	(GX) ACS or (GX) ALS or (GX) SCS
	Section size	With minimum circumscribed association criteria	(GN) ACS or (GN) ALS or (GN) SCS
		With minimax association criteria	(GC) ACS or (GC) ALS or (GC) SCS
		Calculated size with circumference diameter	(CC)
		Calculated size with area diameter	(CA)
		Rank-order size of all types of local size	Example: (LP) (SA) ACS
	Portion size of length <i>L</i>	With least-squares association criteria	Example: (GG) / 20
		With maximum inscribed association criteria	Example: (GX) / 20
		With minimum circumscribed association criteria	Example: (GN) / 20
		With minimax association criteria	Example: (GC) / 20
Calculated size with volume diameter		Example: (CV) / 20	
Rank-order size of section size or spherical size or two-point size		Example: (LP) (SA) ACS (SX) A ↔ B	
Global size	Direct global size	With least-squares association criteria	(GG)
		With maximum inscribed size	(GX)
		With minimum circumscribed size	(GN)
		With minimax association criteria	(GC)
	Calculated global size	Calculated size with volume diameter	(CV)
	Indirect global size	Rank-order size based on a local size	Example: (GN) ACS (SX)
Local and global size	Envelope requirement	Combination of (LP) and (GX) or (GN)	(E)

5 Default specification operator for size

5.1 General

The size operator defined in this part of ISO 14405 only deals with features of linear size which can be a cylinder, a sphere, two parallel opposite planes, a circle (the intersection of a revolute surface and a plane perpendicular to the axis of the associated surface), two parallel opposite straight lines (the intersection of a cylindrical surface and a plane containing the associated axis of the cylindrical surface or a prismatic surface and a plane perpendicular to the associated median plane of the prismatic surface), and two opposite circles (the intersection of a pair of coaxial revolute surface and a plane perpendicular to the axis of the revolute surface).

When the basic GPS indication is used for linear size, the default specification operator for size applies. The default specification operator for size can be the following:

- the ISO default GPS specification operator (see [5.2](#) and ISO 8015);
- the drawing-specific default GPS specification operator (see [5.3](#));
- the altered default GPS specification operator (see ISO 8015).

The basic GPS specification for linear size has no specification modifier attached and can be one of five types (see [Table 4](#)).

NOTE The specification with the ISO tolerance code or with upper and lower values is equivalent.

Table 4 — Different basic GPS specifications for size

Basic GPS specification for linear size	Examples ^a			Figure
Nominal size ± deviation limits	0 150 -0,2	+0,2 ∅38 -0,1	55 ± 0,2	11
Nominal size followed by tolerance code in accordance with ISO 286-1	100 h8;	∅67 k6;	165 js10	12
Values of upper and lower limits of size	150	∅38,2	55,2	13
	149,8	∅37,9	54,8	
Values of upper or lower limits of size	85,2 max.		84,8 min.	—
General tolerancing defined by a nominal size neither indicated in brackets nor as a theoretically exact dimension (TED) (squared dimension)	10 and in the title block ISO 2768-m ^b			—

^a Deviation limits of values for upper and lower limits of size can be written in one line, see [6.2.2](#).
^b See ISO 2768-1 for information on general tolerancing.

5.2 ISO default specification operator for size

The ISO default specification operator for size (without specification modifier) is the two-point size.

The ISO default specification operator for size applies when there is no indication on the drawing referring to another default specification for size as defined in [5.3](#). The consequences of this default definition are given in [Annex C](#).

If the two-point size (default) is applied for both specified limits, the (LP) modifier shall not be indicated. The specifications of [Figures 11](#) to [13](#) use the ISO default specification operator for size and are identical, but written in different ways.

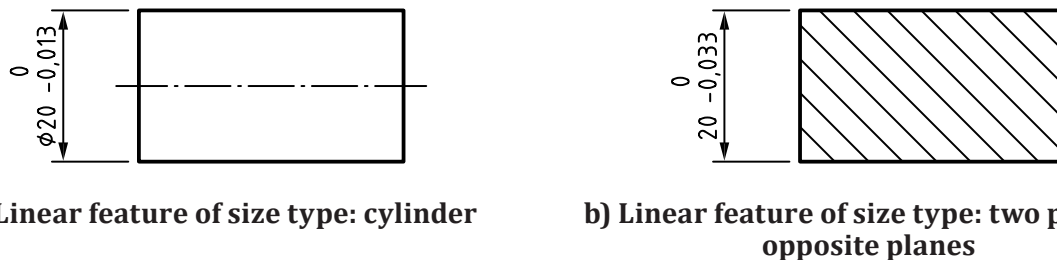

Figure 11 — Example of ISO basic GPS specification of size — Nominal size ± deviation limits

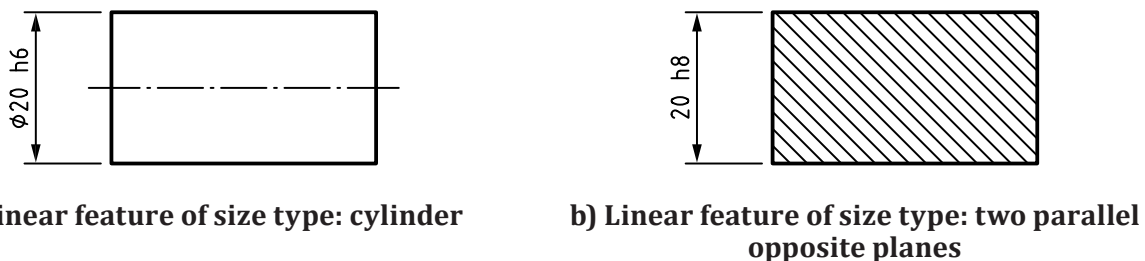

Figure 12 — Example of ISO basic GPS specification of size — Nominal size followed by ISO tolerance code — ISO 286-1

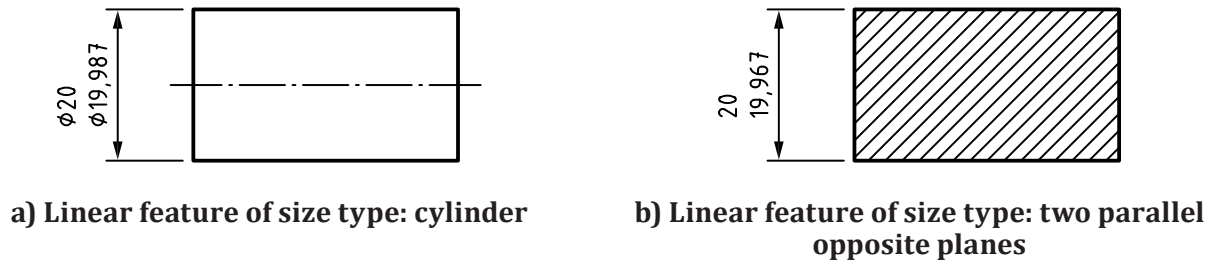

Figure 13 — Example of ISO basic GPS specification of size — Values of upper and lower limits of size (ULS and LLS)

If the two-point size is applied only for one of the two specified limits, the (LP) modifier shall be indicated after the relevant limit of size or deviation limit (see 6.2.2).

5.3 Drawing-specific default specification operator for size

When a drawing-specific default specification operator (see ISO 17450-2) for size applies, it shall be indicated on the drawing in or near the title block in the following order:

- a reference to this International Standard, i.e. “Linear size ISO 14405”;
- the specification modifier(s) for the chosen default definition of linear size.

To facilitate the reading of the drawing, it is possible to indicate all other types of modifier used on the drawing by listing them in brackets after the drawing-specific default specification indication [see Figure 14 b)].

See also Figure 14.

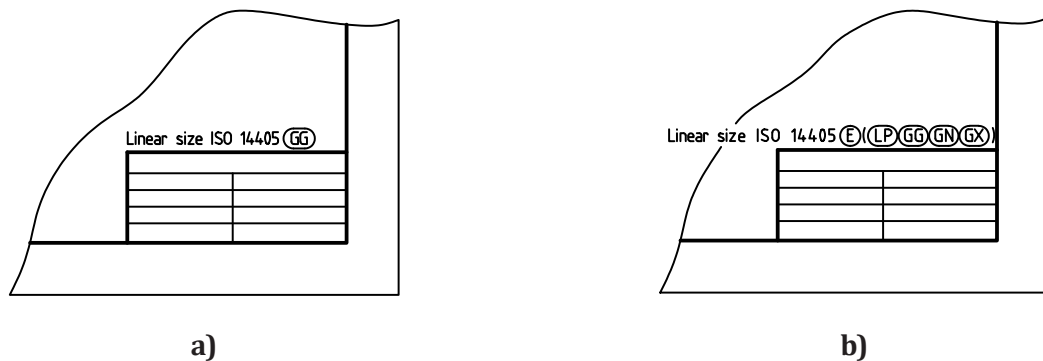

NOTE The default specification operator for this drawing is not the two-point size, but is changed to least squares size [see Figure 14 a)]. Other examples can be the following:

- “Linear size ISO 14405 (E)” changing the default specification operator to the envelope requirement [see Figure 14 b)];
- “Linear size ISO 14405 (CC)” changing the default specification operator to the circumference diameter, etc.

Figure 14 — Example: Change of default specification operator for linear size for the entire drawing

6 Drawing indication for special specification operators for size

6.1 Basic specification

6.1.1 General

A tolerance indication for size by default applies to one single complete feature of size (see [6.2](#) and [7.1](#)). It is possible to indicate that

- a) the tolerance applies to any restricted part or a fixed restricted portion of the feature of size (see [7.2](#), [7.3](#), [7.4](#), and [7.5](#)), or
- b) that the tolerance applies to more than one feature of size (see [7.6](#) and [7.7](#)).

When the ISO default specification operator for size characteristics does not apply, specification modifiers (see [Tables 1](#) and [2](#)) shall be used to indicate which special specification operator(s) applies (see ISO 17450-2:2012, 3.2.7).

The specification modifiers shall be used together with the basic GPS specification for size (see examples of indication in [Table 1](#)) or by given the tolerance when the size characteristic is attached to a range of sizes or a standard deviation of sizes (see example of indications in [Figure 17](#)).

6.1.2 Rules to indicate a basic GPS specification

A basic GPS specification for size as given in [Table 1](#) can be written on one or two lines.

When a GPS specification for size has:

- two deviation limits symmetrical to zero (see [Figure 25](#)), or
- two deviation limits defined by a tolerance code (see [Figure 12](#) and ISO 286), or
- it is defined from a general tolerance or as unilateral limit,

then the specification of size is indicated on one line (expressing the same specification operator for the upper and lower limits of size except when the envelope requirement indicator is used) (see [6.2.1](#) and [6.2.2](#)).

- The nominal value of the size shall be preceded without a space by the symbol \varnothing when the feature of size is a circle or a cylinder, or $S\varnothing$ when it is a sphere.
- If the feature of size shall be specified not using general tolerancing, then the previous indication shall be followed by a space:
 - the deviation limit preceded by “±” indication (see [Figure 29](#)), or
 - the ISO code (see [Figure 12](#)), or
- the “min.” or “max.” indication, respectively, to specify only the lower tolerance limit or the upper tolerance limit (see [Figure 21](#)).

When a GPS specification for size is defined by two deviation limits or two size limits, then this dimensional specification is written on two lines (see [Figures 11](#) and [13](#)).

- The lower line contains the nominal value or the lower size limit which shall be preceded without a space by the symbol \varnothing when the feature of size is a circle or a cylinder, or $S\varnothing$ when it is a sphere and, in the case of a nominal value, followed by the lower deviation limit preceded by a space.
- The upper line contains
 - the upper deviation limit (without indication of the nominal value of the size), or

- the upper size limit which shall be preceded without a space by the symbol \varnothing when the feature of size is a circle or a cylinder, or $S\varnothing$ when it is a sphere.
- The tolerances are aligned using the decimal divider (the comma).

A deviation limit (lower or upper) shall be signed, i.e. preceded by its sign (+ or -) without space when its value is different from zero. When a deviation limit (lower or upper) is equal to zero, then the sign + or - shall be omitted.

The modifier “ $n\times$ ” for more than one feature shall be placed in front of the dimensional specification indication, e.g. $2\times$ or $5\times$ (see 7.6 and 7.7) followed by a space.

6.1.3 Rules to indicate basic dimensional specification with modifiers

After the tolerance value or the tolerance code or the value(s) of the limit of size, the other specification modifiers shall be used in the following order (some modifiers may be omitted in a tolerance specification):

- modifier for type of size characteristic: local size or global size or calculated size, e.g. \textcircled{LP} , \textcircled{GG} , \textcircled{CC} , or \textcircled{E} ;
- modifier for any restricted portion or any cross section or any longitudinal section of the complete feature, e.g. “/25” or “ACS” or “ALS” (see 7.3 and 7.4). If the dimensional specification is applied to any restricted portion or any cross section or any longitudinal section of a geometrical feature, then the corresponding modifier can be preceded by a rank-order modifier, e.g. \textcircled{SX} , \textcircled{SN} , or \textcircled{SA} to define a global characteristic for each portion or each section. (see Example 1);
- modifier for specific cross section “SCS” (see 7.5); with the list of one or more specific cross sections when an ambiguity may exist; modifier for rank-order, e.g. \textcircled{SX} , \textcircled{SN} , or \textcircled{SA} which can precede a sequence of implicit or explicit modifiers that define a local characteristic (see Example 2). To define a global characteristic when the toleranced feature is “any portion” or “any cross section” or “any cross section within a portion” of the linear feature of size, the rank-order modifier shall be placed after the modifier for restricted portion or a cross section of the complete feature, e.g. $25 \pm 0,1 \textcircled{GG}/25\textcircled{SA}$ or $12 \pm 0,05 \textcircled{GG}ACS\textcircled{SX}$;
- indication of the specific portion with between symbol (see 7.2 and 7.3);
- modifier for common toleranced feature of size, i.e. “CT” (see 7.7); a rank-order modifier (e.g. \textcircled{SX} , \textcircled{SN} , or \textcircled{SA}) can precede the CT modifier e.g. $2\times 150 \pm 0,05 \textcircled{GG} ACS \textcircled{SA} CT$;
- modifier for free state condition, i.e. \textcircled{F} (see 7.8);
- intersection plane when it is necessary to clarify the ALS or ACS indication (see 7.4) followed by a direction feature when it is necessary to clarify the direction of the dimension to be considered and by this way, an orientation constraint of association $10 \pm 0,03 \textcircled{GN} ALS \begin{array}{|c|} \hline \text{---} \\ \hline \end{array} A \begin{array}{|c|} \hline \text{---} \\ \hline \end{array} A$ (see Figure 28);
- flag note indicator (see Clause 8).

EXAMPLE 1 The sequence of modifiers, $\textcircled{LP} \textcircled{SD} ACS$, means the mid-range (rank-order) size of the local two-point sizes is calculated in each cross section separately. This defines a local characteristic for each cross section.

EXAMPLE 2 The sequence of modifiers, $\textcircled{LP} \textcircled{SD} ACS \textcircled{SR}$, defines the same set of local characteristics as in Example 1 and from that set the range (rank-order) of sizes is calculated. This defines a global characteristic.

NOTE 1 If a local size is required without any other rank-order modifier, the operators for maximum rank-order size \textcircled{SX} and for minimum rank-order size \textcircled{SN} apply by default to the upper and lower limits of size, respectively. For example, when the default size characteristic is the two-point size, the following size requirements are identical.

150 [+0,1] - [-0,1]

150 [+0,1(LP)] - [-0,1(LP)]

150 [+0,1(LP)(SX)] - [-0,1(LP)(SN)]

When the set of specification modifiers applies to both the upper and lower limits of size, only one set of specification modifiers shall be used (see [Figures 15, 16, 17, 24, 26, 27, 28, 29, 30, 31, 32, 33](#) and [34](#)).

When different specification modifiers are chosen for the upper and lower limits of size, it creates two different characteristics and a set of specification modifiers shall be attached to each deviation limit indication (upper and lower) (see [6.2.2](#)). The indication of the specification modifier $\text{\textcircled{C}}$ is the unique exception to this indication rule.

NOTE 2 When several specifications apply to the same size, each specification is independent. There may be a mathematical relationship between the different characteristics defined by the specifications, e.g. the minimum circumscribed diameter is always larger than least squares diameter.

EXAMPLE 3 In [Figure 17 a\)](#), the first characteristic, which is the range of local two-point sizes and the second characteristic, which is the median of local two-point sizes, shall be considered independently. In [Figure 19 a\)](#), the characteristic for the upper limit of the specification can mathematically never be lower than the characteristic for the lower limit of the specification. In [Figure 20 a\)](#), the characteristic for the lower limit of the upper specification and the characteristic for the lower limit of the lower specification are the same.

When a range of sizes (rank-order) or standard deviation of sizes (rank-order) is required, a nominal size value shall not be indicated. In this case, the specified value indicated is by default (without the additional indication “max.”) the upper limit of the range of sizes or standard deviation of sizes as defined in [Clause 5](#). For example, 0,004 $\text{\textcircled{SR}}$ means that the difference between the maximum value and the minimum value of the two-point size characteristic shall be $\leq 0,004$ (see [Figure 17](#)).

When a unilateral tolerance indication is used, the modifiers shall be placed after the “max.” or “min.” symbol, e.g. $\varnothing 54,6 \text{ max. } \text{\textcircled{GG}}$ and $\varnothing 45,9 \text{ min. } \text{\textcircled{GG}}$.

6.2 Indication of special specification operators

6.2.1 One specification operator for both limits (upper and lower) of a size characteristic

If the same special specification operator applies to the upper limit of size, as well as the lower limit of size, only one set of specification modifiers shall be used (see [Figures 15, 16, and 17](#)).

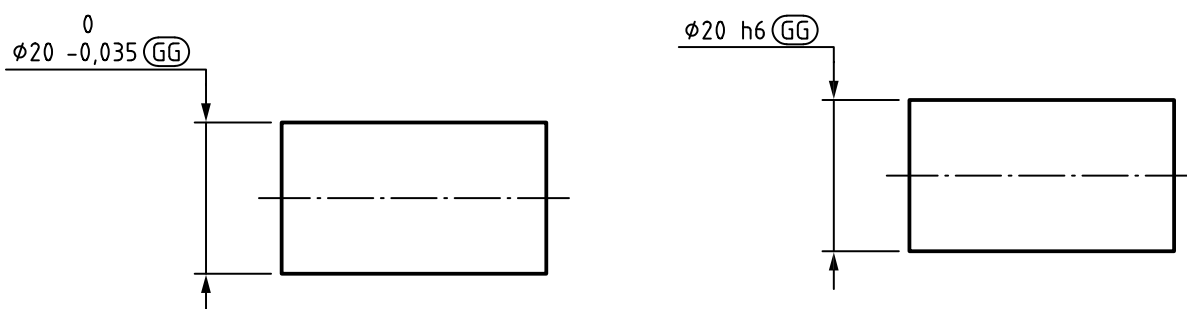

a) Special specification operator for size based on deviation limits

b) Special specification operator for size based on tolerance codes in accordance with ISO 286-1

NOTE The specification operator “least-squares size” applies to the upper, as well as the lower deviation limit.

Figure 15 — Example: indication of a special specification operator for size

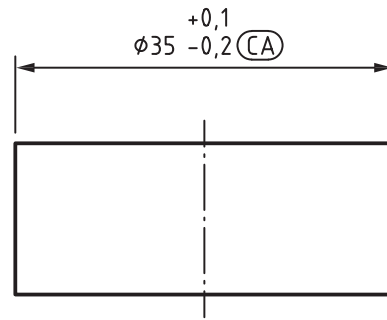

NOTE The specification operator “area diameter” applies to the upper and lower limits of size.

Figure 16 — Example: same specification operator for upper limit of size and lower limit of size

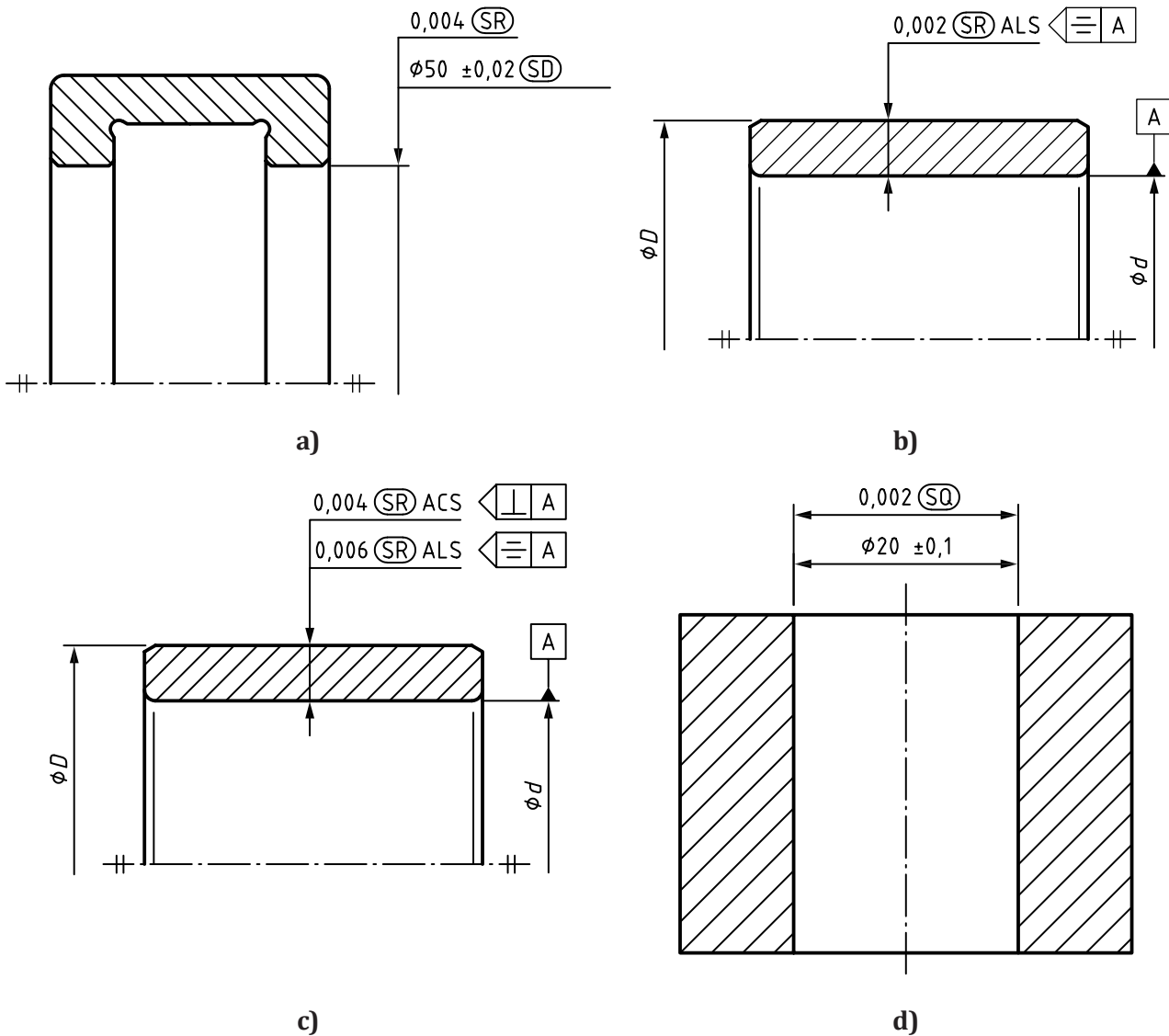

NOTE 1 a) indicated specification operators on the right diameter for the following:

- lower indication: an upper and a lower limit of size ($\phi 50 \pm 0,02$) apply to the mid-range size of the two-point size values;
- upper indication: an upper limit (0,004) applies to the range of the two-point size values.

NOTE 2 b) indicated specification operator for thickness: an upper limit (0,002) applies to the range of the two-point size values of the wall thickness anywhere on the non-ideal-surfaces in any longitudinal section.

NOTE 3 c) indicated specification operators on thickness for the following:

- upper indication: an upper limit (0,004) applies to the range of the two-point size values defined in any cross section;
- lower indication: an upper limit (0,006) applies to the range of the two-point size values defined in any longitudinal section.

NOTE 4 d) indicated specification operators on diameter for the following:

- lower indication: lower and upper limits ($20 \pm 0,1$) apply to the two-point size values defined anywhere on the real surface;

- upper indication, an upper limit (0,002) applies to the standard deviation of the two-point size values defined anywhere on the real surface.

Figure 17 — Examples of the use of rank-order specification modifier

6.2.2 Different specification operator for upper limit of size and lower limit of size

If different specification operators apply for the upper and the lower limit of size, the specification operators are indicated either

- attached to each of the limits of size or deviation limits or tolerance code indications (see [Figures 18](#) and [19](#)), or
- written on the same line in the following order:
 - the specification operator for the upper limit of size, in square brackets;
 - a space, a hyphen, and a space;
 - the specification operator for the lower limit of size, in square brackets.

NOTE When different specification operators are applied for the upper limit and the lower limit, each specification operator is described using modifiers, even if one is the default operator.

EXAMPLE $+0,2 \text{ (GN)}/15$
 $2 \times \phi 78 -0,2 \text{ (LP) (SA)}$ or $2 \times \phi 78 [+0,2 \text{ (GN)}/15] - [-0,2 \text{ (LP) (SA)}]$

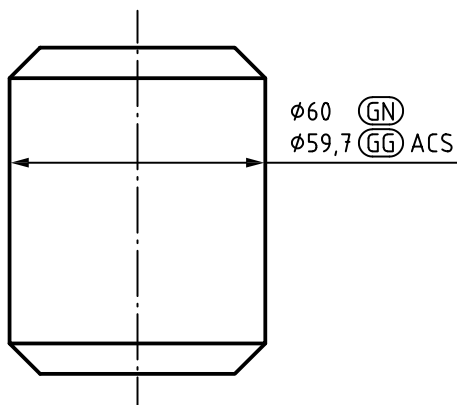

a) Indication of different characteristics for lower and upper limits of size

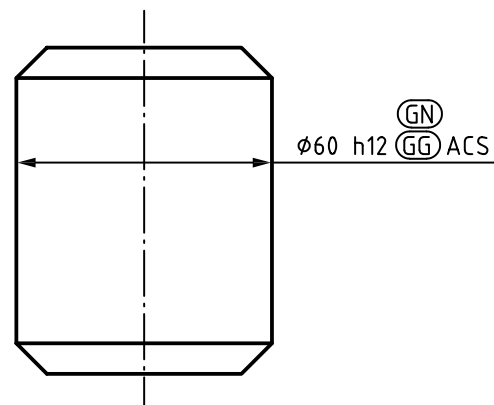

b) Indication of different characteristics when using nominal size and tolerance code (see ISO 286-1)

NOTE a) and b) express the same requirements. The specification operators defining the size characteristic are, for the upper limit, the “minimum circumscribed” cylinder diameter and, for the lower limit, the “least squares” diameter in any cross section.

Figure 18 — Example of different specification operators for the upper and lower limits of size

The envelope requirement, $\text{\textcircled{E}}$, is a simplified indication to describe two specification operators where the local size exists on the linear feature of size. It is equivalent to express two separate requirements, one for the upper limit of size and another for the lower limit of size by using the modifier $\text{\textcircled{GX}}$ for an internal feature (e.g. hole), or $\text{\textcircled{GN}}$ for an external feature (e.g. shaft) for the maximum material side of the tolerance (upper or lower tolerance), and the modifier $\text{\textcircled{LP}}$ for the other side of the tolerance (see Figure 19).

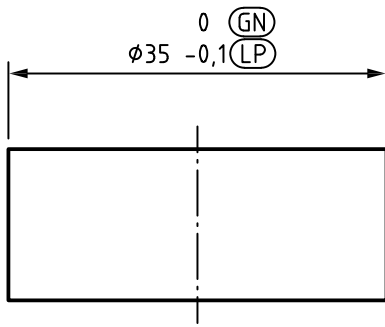
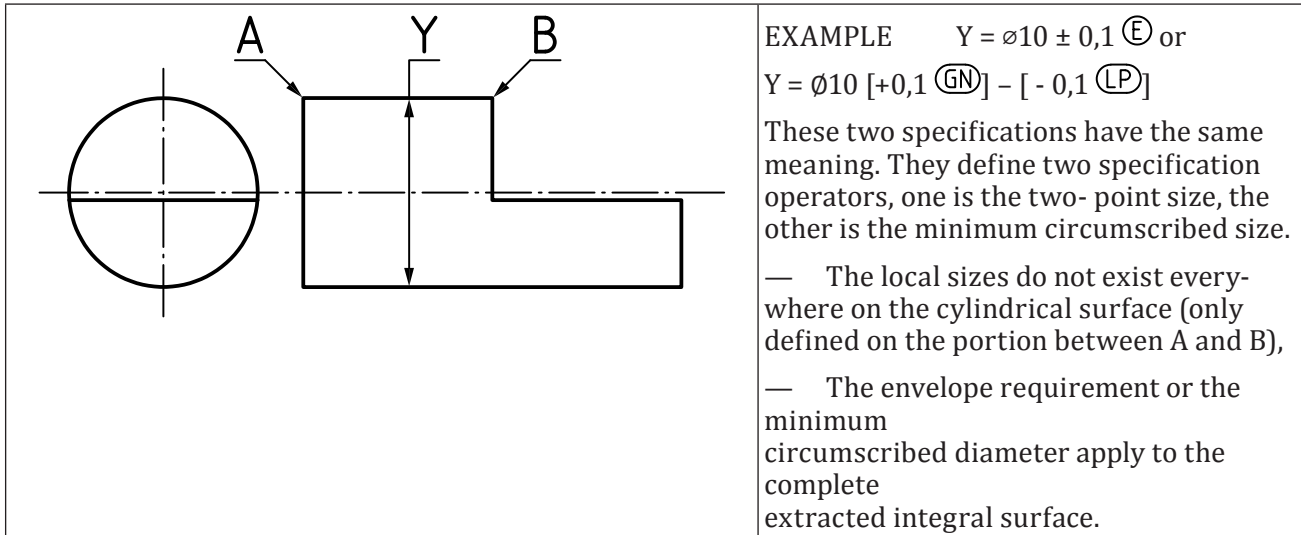

a)

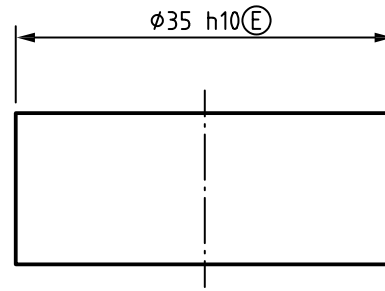

b)

NOTE 1 There are two specification operators indicated describing two size characteristics which are the following:

- “minimum circumscribed” associated cylinder diameter which applies to the upper limit;
- “two-point” diameter which applies to the lower limit.

NOTE 2 When the extent of the figure of size is relatively small compared to the size, or when the removed portion on the feature of size is large (compared to the complete mathematical feature), then the evaluation the size can exhibit instability which can be limited, e.g. by using a direction feature.

Figure 19 — Possible indications to express the envelope requirement

6.2.3 More than one dimensional specification applied to a linear feature of size

When there are only two specification operators, it is possible to express them as defined in 6.2.2 or by expressing these by two separate specifications by using the indication “min.” or “max.”.

If more than two specification operators are applied to a feature of size, they shall be specified by the following:

- on separate dimension lines [see Figure 20 a)], each containing one or two specification operators, when possible;
- with one dimension line, on which are indicated directly [see Figures 20 b)] or indirectly with an attached reference line [see Figure 20 c)] more than one dimensional specification separated by a dash and each being written into squared brackets;
- with one dimension line, attached to several reference lines, each one containing one or two specification operators [see Figure 20 d)] and Figure 21].

NOTE If the space is not sufficient on the dimension line, the specifications can be placed on a reference line connected to the dimension line with a leader line (see Figure 20 c).

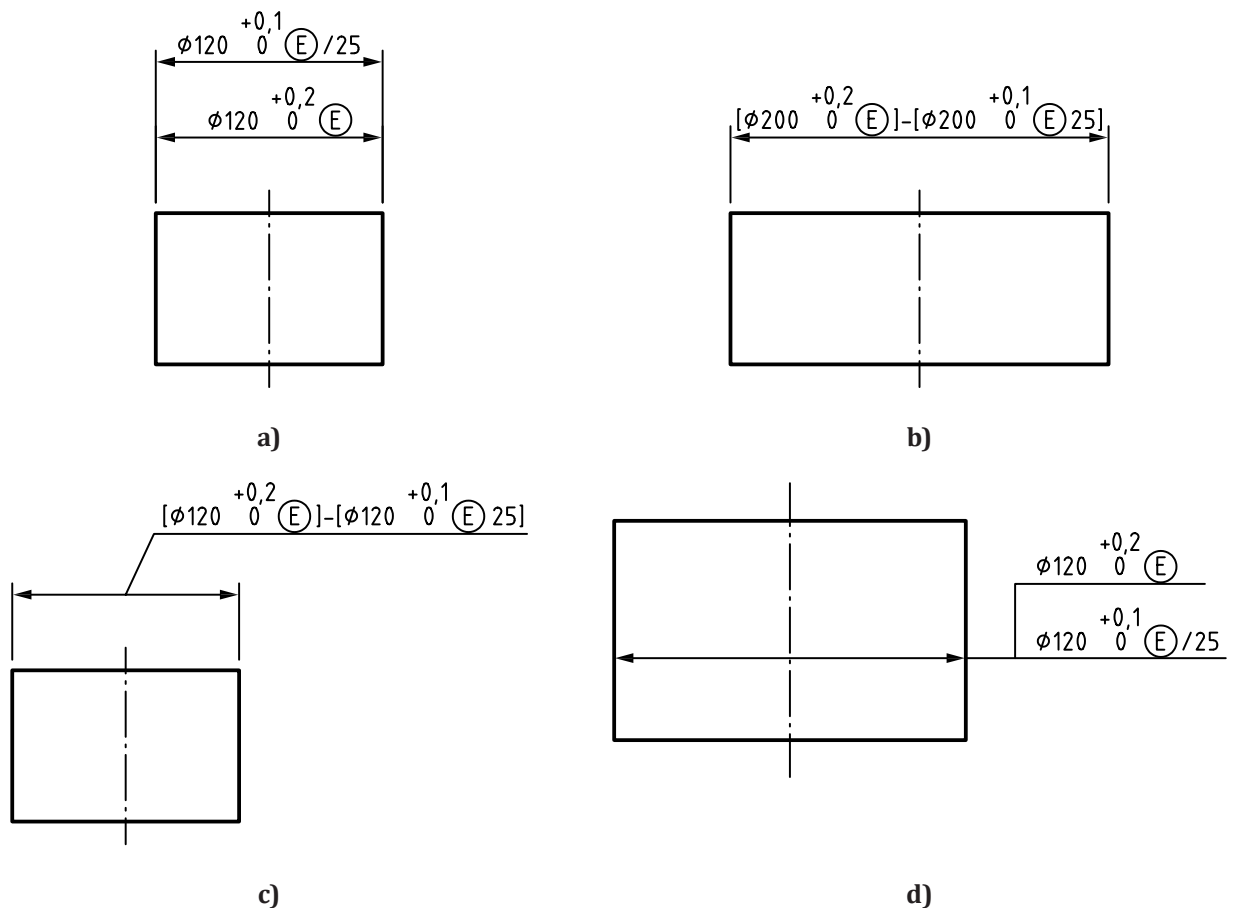

NOTE The two specification operators indicated in a), b), c) and d) are the following:

- the envelope requirement $0/+0,2$ for the complete linear feature of size;
- the envelope requirement $0/+0,1$ for any restricted length of 25 mm of the linear feature of size.

Figure 20 — Example of more than one requirement for size on the same linear feature of size

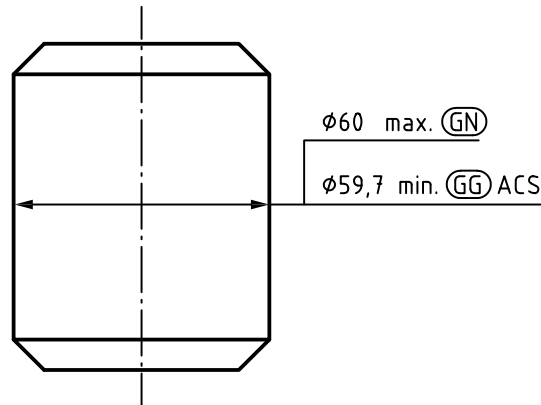

NOTE This figure expresses the same requirements as expressed on [Figure 18](#).

Figure 21 — Example of two requirements for size characteristics on the same linear feature of size

6.3 Tolerancing of fits on assembly drawings

Dimensioning and tolerancing of a fit may take place on an assembly drawing eliminating the possibility for misinterpretation (see [Figures 22](#) and [23](#)).

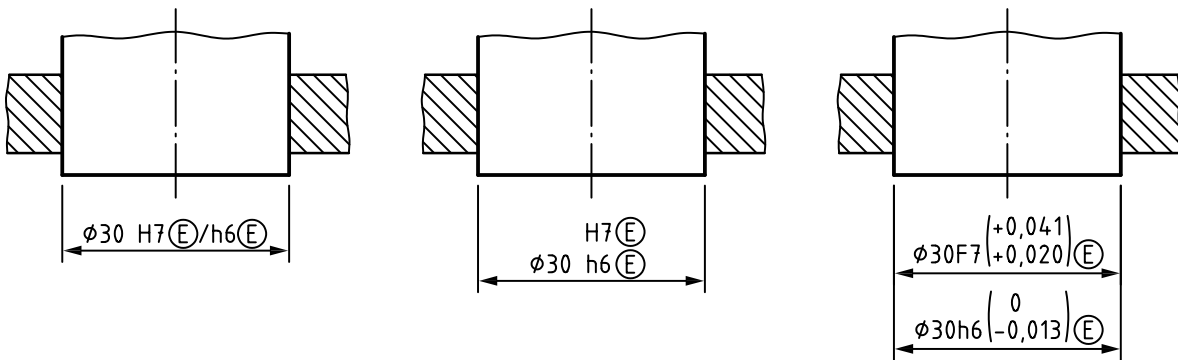

Figure 22 — Examples of assembly drawing with ISO code system tolerancing of two features in a fit

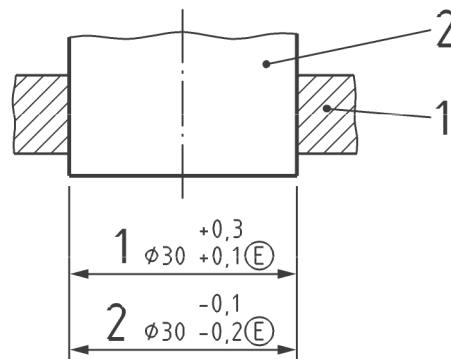
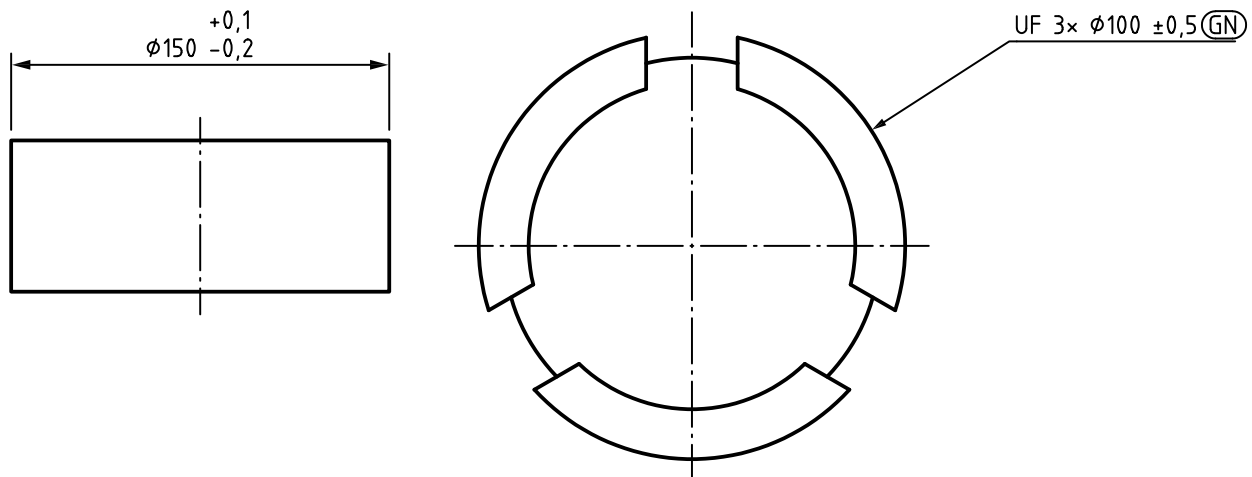

Figure 23 — Examples of assembly drawing with plus and minus tolerancing of two features in a fit

7 Indication of the tolerated feature on which the size characteristic is defined

7.1 Complete tolerated linear feature of size

The specification applies by default to the complete tolerated feature of size. When the tolerated feature is the complete feature, no additional indication is necessary [see [Figure 24 a](#)]. When the specification applies to a united feature (UF) of size, the specification shall be preceded by UF $n \times$ [see [Figure 24 b](#)].



a) Requirement for the complete feature of size

b) Requirement for the complete united feature of size

NOTE The specification operators indicated in a) are the default operators. The two-point diameter applies to both the upper and the lower limits for the entire feature of size.

Figure 24 — Example of requirement for the complete feature of size

7.2 Specific fixed restricted portion of the feature of size

If the specification applies to only one fixed restricted portion of the complete feature of size, it shall be indicated by the following:

- a long-dashed dotted wide line placed over the restricted portion of the complete feature with the indications of the dimensions defining its extent and its location [see [Figure 25 a](#)], or
- using two letters defining the beginning and the end of the fixed restricted portion. These two letters follow the tolerance of the size and are separated by the “between” symbol [see [Figure 25 b](#)].

The extent of the portion and its location shall be defined by theoretical exact dimensions (TEDs).

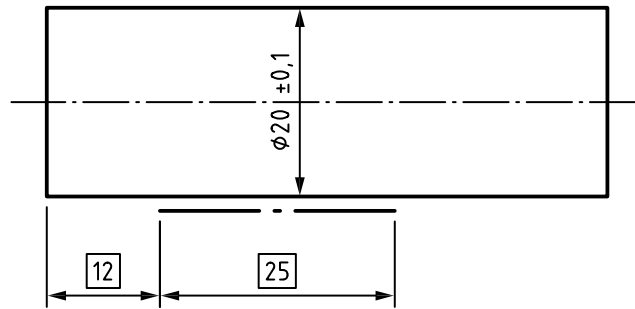

a) Restricted portion defined by using a wide, long dashed-dotted line

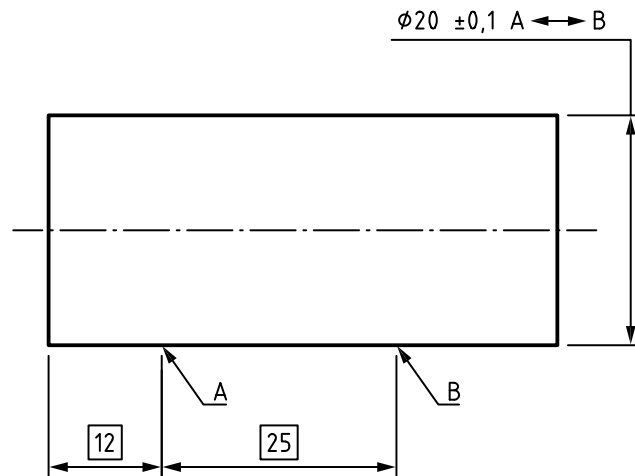

b) Restricted portion defined by using the \leftrightarrow symbol

NOTE The specification operators indicated are the default operators. The two-point diameter applies to both the upper and lower limits of size for the restricted portion of the feature of size.

Figure 25 — Example of requirement for a specified fixed restricted portion of the feature of size

7.3 Any restricted portion of the feature of size of a specified length

If the specification applies to any restricted portion of either the complete feature of size or a fixed restricted portion of it, it shall be indicated in the sequence of the specification with the specification modifier “/” followed by the value of the length of the restricted portion (considered as a TED) [see Figure 26 a)]. The indication “/0”, meaning that the length of the restricted portion is zero, is equivalent to the “ACS” modifier (see 7.4). It is recommended to use the “ACS” modifier in this case.

If any of these restricted portions are taken on a fixed restricted portion of the complete feature of size, this restricted portion shall be indicated by

- using a long-dashed dotted wide line with the dimension line pointed to it [see Figure 26 a)]. or
- using two letters defining the beginning and the end of the restricted portion and indicating in the sequence of specification these two letters separated by the “between” symbol [see Figure 26 b)].

The extension and the location of the restricted portion shall be indicated by TEDs.

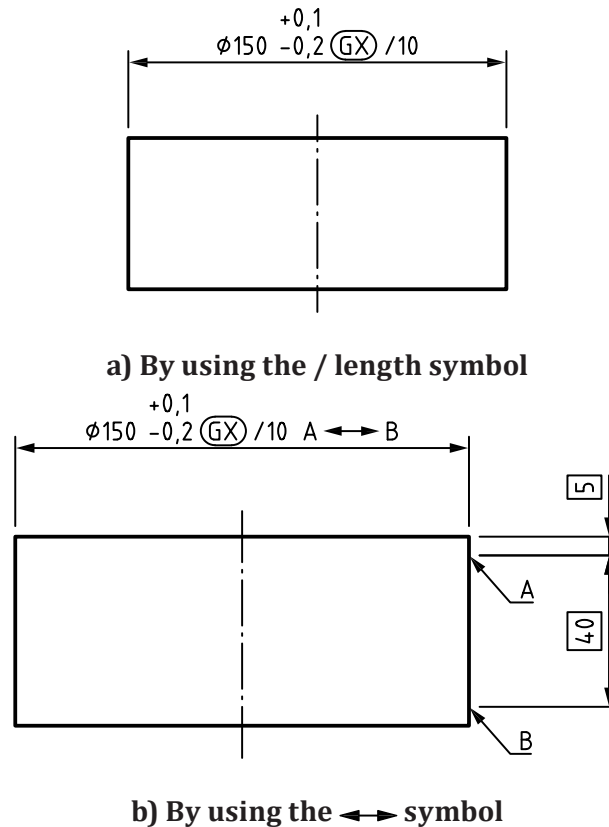

NOTE The same specification operator applies to both the upper and lower limits of size and defines as size characteristic the maximum inscribed cylinder diameter for any portion of the indicated length.

Figure 26 — Example of requirements for any restricted portion of the feature of size

7.4 Any cross section or any longitudinal section of a linear feature of size

If the specification applies to any cross section or any longitudinal of either the complete feature of size or a fixed restricted portion of it, it shall be indicated with the specification modifier “ACS” for any cross section or with the specification modifier “ALS” for any longitudinal section in a view or a section (see [Figures 27](#) and [28](#)), respectively. Moreover, if any cross sections or any longitudinal sections are taken on a restricted portion of the complete feature of size, then the restricted portion shall be indicated by using a long-dashed dotted wide line or by using the “between” symbol. For the extent of a specification for a restricted portion, see [Figure 26 b](#)).

A cross section is defined to be perpendicular to an axis. A longitudinal section is defined as a half plane including an axis. By default, if this axis shall be the axis of associated feature of size itself, then the intersection plane can be omitted, otherwise, it shall be specified with an intersection plane indicator.

When the size to be considered is a thickness (e.g. distance of two straight lines or distance between two circles), then an intersection plane indicator shall be used as a complement to ALS or ACS to specify the feature of size which establishes the intersection plane.

The intersection plane indication is always placed at the end of the sequence of dimensional specification elements followed, if necessary, by a direction feature indicator [see [Figure 28 a](#))], but before the flagnote indicator.

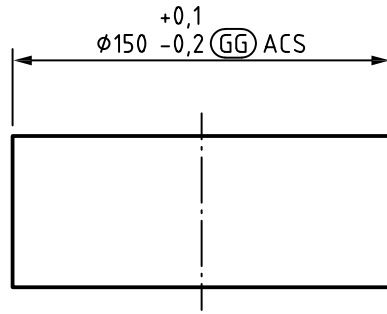

a) Indication in a view

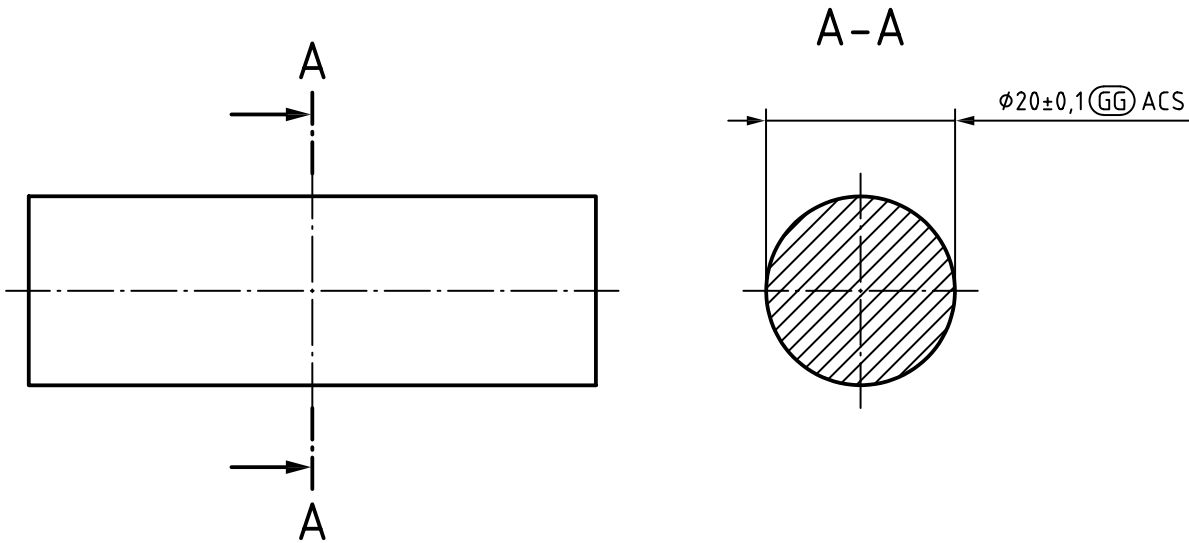

b) Indication in a cross section

NOTE The specification operator “least-squares diameter” for any cross section of the cylindrical feature applies to both the upper and lower limits of size.

Figure 27 — Example: Using the ACS modifier to express a requirement for any cross section of the linear feature of size

<p>a) Indication</p>	<p>The size (characteristic) is the (local) minimum circumscribed size in any longitudinal section defined between two extracted integral lines (the intersection of the extracted integral feature of size and an intersection half plane including datum A) in a direction parallel to datum A (to avoid instability when the extent of the opposite areas is small).</p> <p>b) Meaning</p>
----------------------	---

Figure 28 — Example: Using the ALS modifier in conjunction with an intersection plane and a direction feature

7.5 Size characteristic in a specific cross section of a feature of size

If the specification applies to a specific cross section of the complete feature of size, then

- a) the cross section shall be indicated by identifying the following:
 - the dimensional specification in the considered cross section [see [Figures 29 a\), b\) and c\)](#)];
 - the cross section with a leader line connected to a cross section identifier above [see [Figure 29 d\)](#)];
 - by using as the departure point the oblique extension lines from which the dimension line is connected (see [Figure 31](#)),
- b) the location of the cross section from another geometrical feature shall be defined by a TED, and
- c) the modifier SCS shall be indicated in the dimensional specification followed by the identifier of the cross section placed into squared bracket [see [Figures 29 a\), 29 c\), 29 d\)](#), and [31](#)].

When no confusion about the nature of the specific cross section is possible, the symbol “SCS” can be omitted [see [Figure 29 b\)](#)].

The location of the cross section should not be at the beginning or the end of the feature (defining an implicit TED of 0 mm) to ensure that the cross section exists on the real workpiece.

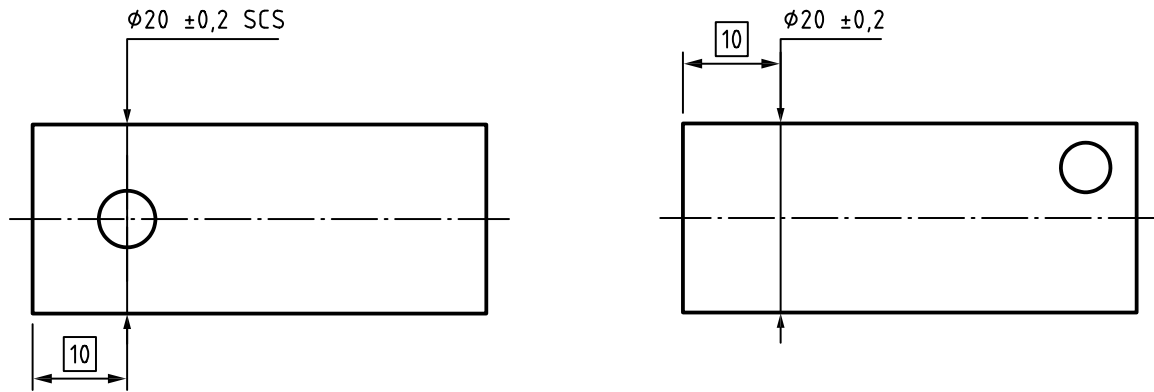

a) Location of the cross section and indication in the same view with the modifier “SCS”

b) Location of the cross section and indication in the same view without the modifier “SCS”

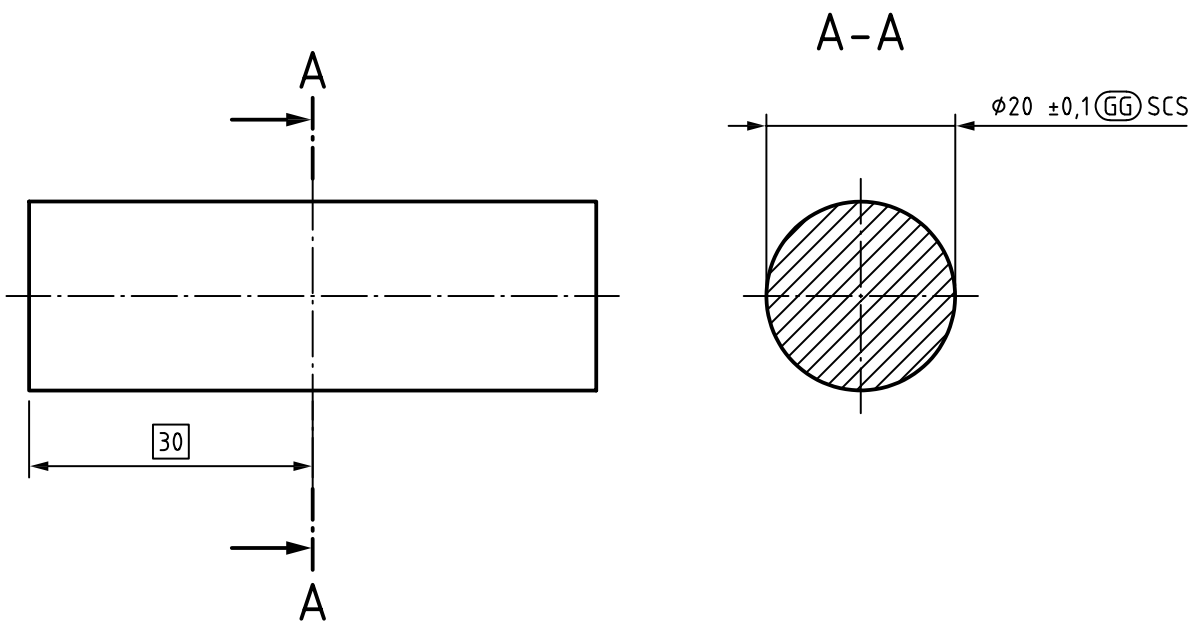

c) Location of the cross section in a view and indication in this cross section

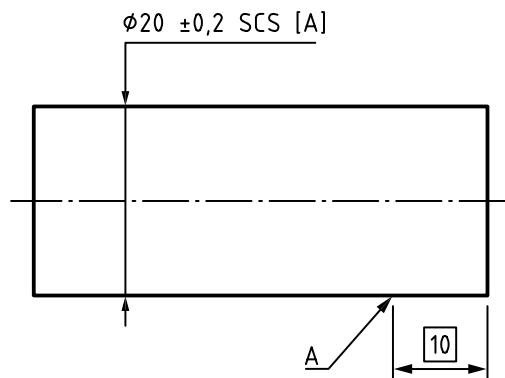

d) Dimensional specification with SCS Symbol

NOTE In a), the modifier SCS defines without ambiguity that the specification applies only in a specific location: the TED 10 could be used for a geometrical specification of location.

Figure 29 — Example of an indication for a specific cross section of the complete feature of size

When a specification applies to several specific cross sections of the same feature of size, then each cross section shall be identified by an identifier and the series of identifiers shall be placed after the modifier SCS into squared brackets, each separated by a comma and a space. If a rank order is to be applied on this set of size characteristic, then the rank order modifier shall be placed after the identifiers of the series of specific cross sections (see [Figure 30](#)).

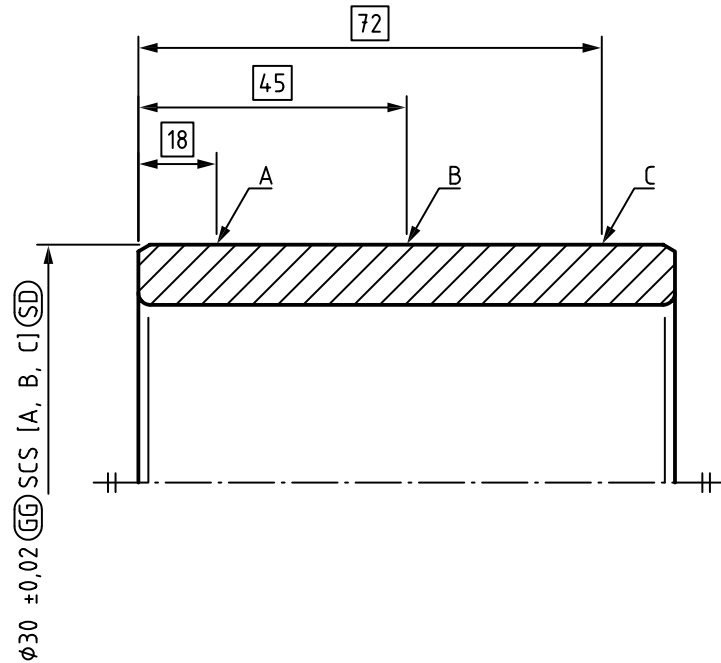
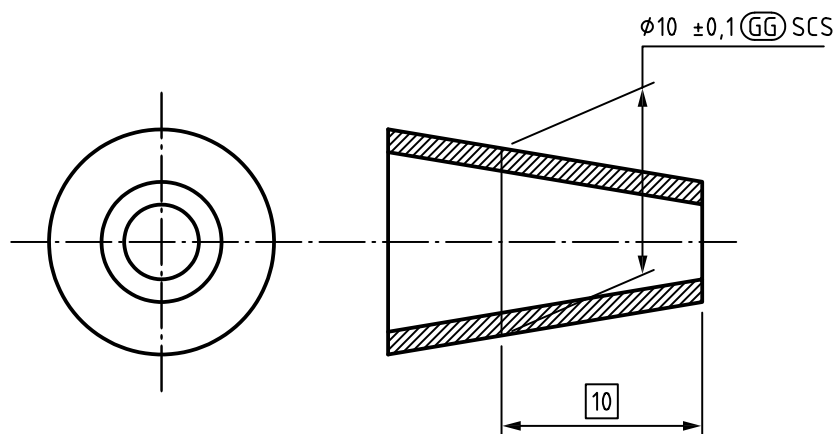

Figure 30 — Indication of several specific cross sections



NOTE This figure is provided to show an indication of a diameter in a specific cross section of a cone.

Figure 31 — Example of an indication in a specific cross section of a cone

7.6 Requirement applied individually for more than one feature of size

If the specification applies as an individual requirement for more than one feature of size, the specification modifier “n×” shall be placed as the first element in the specification to indicate the number of features to which the specification applies (see [Figure 32](#)).

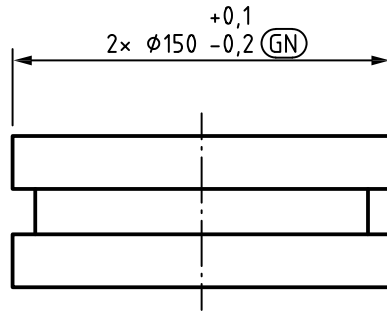

NOTE The specification operator “minimum circumscribed cylinder diameter” applies to the upper and lower limits for the two cylindrical surfaces individually.

Figure 32 — Example of individual requirements for two features of size

NOTE This specification modifier “n×” can only be used when there is no doubt as to which features the specification applies.

7.7 Requirement applied for more than one feature considered as one feature of size

If the specification applies to a collection of more than one feature of size and this collection shall be considered as one feature of size, the specification modifier (n×) shall be placed as the first element in the specification to indicate the number of features of size on which the specification applies and the specification modifier “CT” shall be placed at the end of the specification (see [Figure 33](#)).

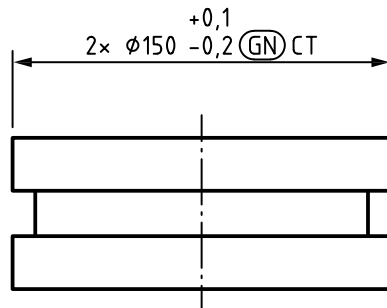

NOTE The specification operator “minimum circumscribed cylinder diameter” applies to the upper and lower limits for the two cylindrical surfaces considered as one feature of size.

Figure 33 — Example of requirement for two features of size considered as one feature of size

7.8 Flexible/non-rigid parts

If the specification applies to a non-rigid part, the specification modifier Ⓢ (see ISO 10579:2010) shall be added to the specification to indicate that it applies to the feature or workpiece in a free-state condition (see [Figure 34](#)).

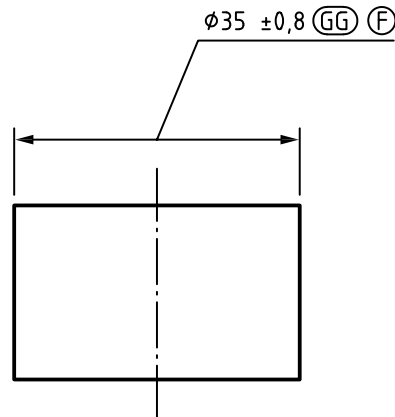

NOTE The specification operator “least squares requirement” applies to the feature in a free-state condition of a flexible workpiece, both for the upper and lower limits of size.

Figure 34 — Example of requirement for free-state condition of a flexible workpiece

8 Complementary indication

When a complementary requirement applies to a dimensional specification, a numbered flagnote shall be placed at the end of the specification. The requirement shall be defined close to the title block or in a complementary document.

EXAMPLE $[10 \pm 0,1 \text{ } \text{\textcircled{1}}] - [10 \pm 0,2 \text{ } \text{\textcircled{2}}]$

with

$\text{\textcircled{1}}$: before heat treatment

$\text{\textcircled{2}}$: after heat treatment

placed close to the title block.

The flagnote can describe the GPS characteristics as the following:

- a calculated characteristic as a function of one or more other GPS characteristics. In this case, each parameter of the function shall be labelled as GPS characteristic on the drawing;
- a constrained characteristic (see ISO 10579 and ISO/TS 17863);
- a characteristic in a special state.

The flagnote can also indicate any other indications common to several specifications as, for example, specific specification operator, constrained conditions, additional requirements for workpieces population, etc.

See [Table 2](#) and [Clause 8](#).

Annex A (normative)

Proportions and dimensions of graphical symbols

A.1 General requirement

In order to harmonize the size of the symbols specified in this part of ISO 14405 with those of other inscriptions on technical drawings (dimensions, geometrical tolerances, etc.), the rules given in ISO 81714-1 shall be applied.

A.2 Proportions

The graphical symbols shall be drawn in accordance with [Figures A.1](#) and [A.2](#).

The symbol XX in [Figure A.1](#) designates all the different letter combinations for the specification modifiers given in [Table 1](#).

The symbol X in [Figure A.2](#) can correspond, in this part of ISO 14405, to the letter E or F for the specification modifiers given in [Table 2](#).

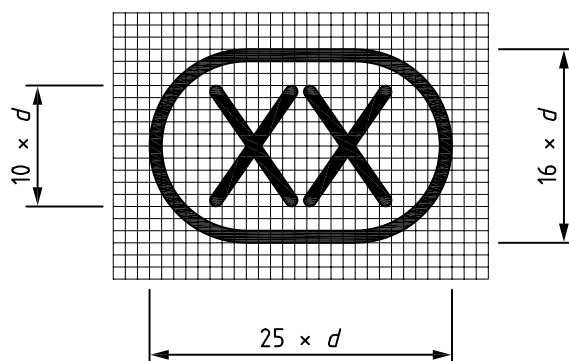

Figure A.1

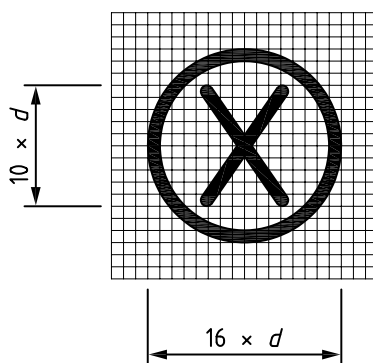

Figure A.2

A.3 Dimensions

The dimensional requirements of the graphical symbols and the additional indications are specified in [Table A.1](#).

NOTE These requirements are in accordance with ISO 3098-2.

Table A.1 — Dimensions

Dimensions in millimetres

Lettering height, h	2,5	3,5	5	7	10	14
Line thickness for symbols and lettering, d	0,25	0,35	0,5	0,7	1	1,4

Annex B (informative)

Overview diagram for linear size

The diagram given in [Figure B.1](#) presents the relations between several types of characteristics relative to the size of a linear feature of size when the latter is applied to the complete feature of size.

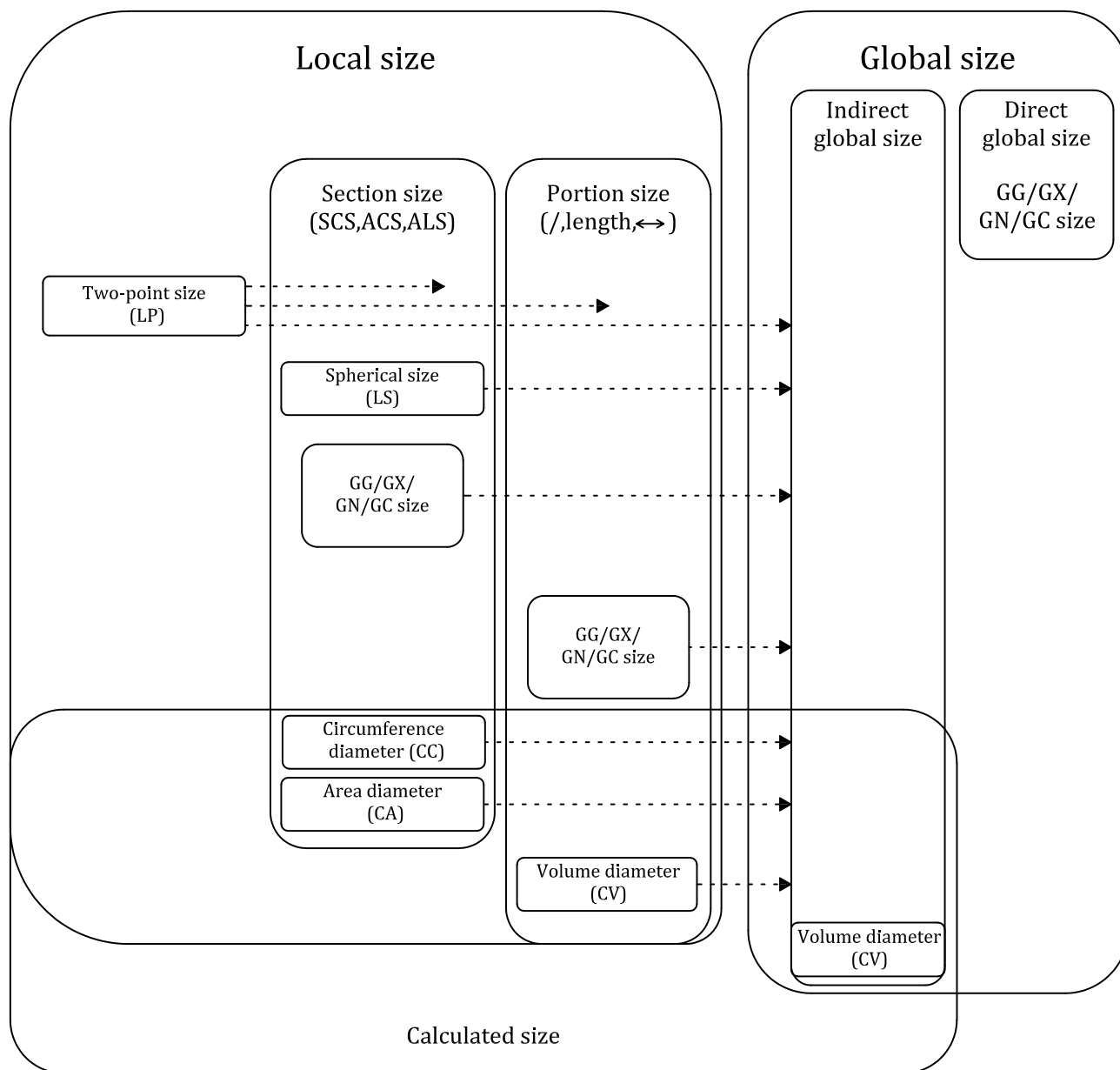

Key

--> defined by a rank-order size from

Figure B.1 — Overview diagram for size

Annex C (informative)

Data handling with rank-order modifiers

If a specification does not apply by restricted portion or section, then all data belong to one set of results.

If a specification applies to a restricted portion or section, then data sets shall be considered by portion or by section. A section data set is defined for each portion or section.

If a global size (including a rank order size) is specified for each portion or section, then each section data set is reduced to one global section value for the section or portion.

If a global size (including a rank order size) is specified for the complete feature of size, then the set of results is reduced to one global value.

Examples of dimensional specifications:

- a) $\varnothing 10 \pm 0,0035$ (LP) (SD) ACS;
- b) $0,005$ (LP) (SD) ACS (SR);
- c) $0,05$ (LP) (SR);
- d) $10 \pm 0,04$ (LP).

Assuming that 12 local two-point sizes have been measured in each of five cross sections as given in [Table C.1](#) (the bold values are maxima or minima within one section).

Table C.1 — Primary data result set (two-point sizes obtained in five sections and in 12 angular locations orientations)

No. <i>j</i> in a section	Angular location in a section in	Section no. <i>i</i>				
		1	2	3	4	5
1	0	10,000	10,000	9,996	9,995	9,990
2	15	10,010	10,015	10,016	10,003	10,008
3	30	10,012	10,009	10,005	10,017	10,008
4	45	10,009	10,007	10,011	10,009	10,013
5	60	10,011	10,010	10,016	10,021	10,007
6	75	10,015	10,025	10,022	10,009	10,006
7	90	10,005	9,997	10,007	10,013	9,996
8	105	10,006	10,002	10,006	10,014	10,014
9	120	10,004	10,012	10,013	10,006	10,006
10	135	9,997	10,002	10,002	9,988	10,002
11	150	9,995	9,986	9,987	9,993	10,000
12	165	9,999	10,008	10,007	10,007	9,996

Table C.2 — Results of evaluation for the three types of specified characteristic

	Result of measurement for this sequence of modifiers					
Ⓟ Ⓞ ACS	10,005	10,0055	10,0045	10,0045	10,0020	—
Ⓟ Ⓞ ACS Ⓢ	—	—	—	—	—	0,0035
Ⓟ Ⓢ	—	—	—	—	—	0,039
Type of size characteristic	Local					Global

EXAMPLE A dimensional specification which is indicated on the drawing by $\varnothing 10 \pm 0,0035$ Ⓟ Ⓞ ACS Ⓢ can be described as a sequence of operations applied to a set of data.

NOTE 1 The specification operator defined by “ $\varnothing 10 \pm 0,035$ Ⓟ Ⓞ ACS Ⓢ” is a GPS operator equivalent to the description of the characteristic V_{dmp} defined textually in ISO 492.

Let i be the cross section index and j the value index in each cross section.

- $LP(i, j)$ represents the value number j evaluated in the section i
- $\mu_i = E_i(LP(i, j))$ represents the average value in section i evaluated from the set of values $LP(i, j)$
- $R = \text{Max}(\mu_i) - \text{Min}(\mu_i)$ represents the range evaluated from the set of values μ_i

The example shows the sequence of operations on the primary data result set. A portion or section requirement (in this case, the “any cross section” requirement) generates a secondary set of section data sets from the primary set. For each data section set, a mid-range value is generated and finally, from the set of mid-range values of individual sections, a range value is calculated. Graphically, this sequence of operations can be depicted as follows, where B is the primary data result set (as given in Table C.1), the C_i are the data section sets for each cross section and R the results for each specified characteristic (see Table C.2) as shown in Figure C.1.

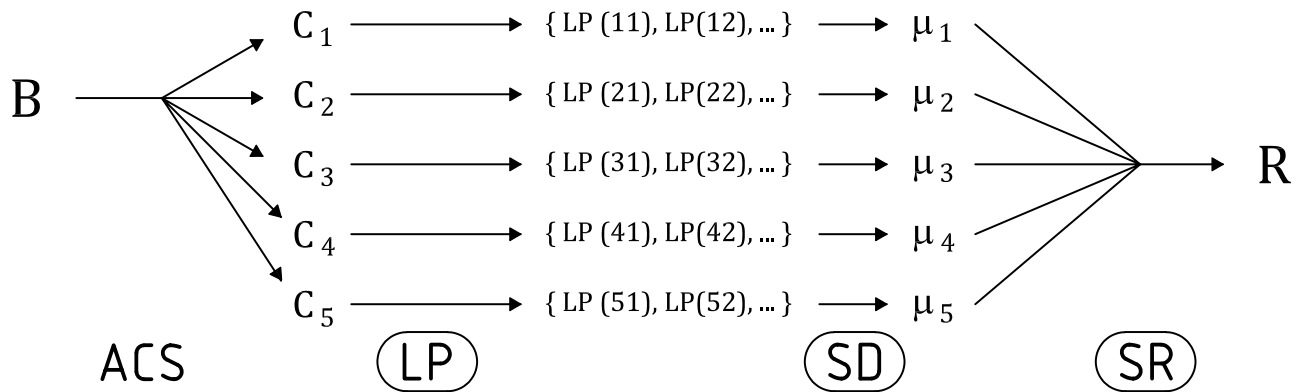

Figure C.1 — Illustration of an example of schematic from the primary set of evaluations to the result on the characteristic

NOTE 2 The sequence of operations on the data set does not always follow the sequence of the modifiers of the specification. For example, the subdivision of the primary data result set by section or portion, if applicable, is always the first operation, regardless of where the corresponding modifier is in the sequence.

Annex D (normative)

Size characteristics

D.1 Two-point size

D.1.1 General

A two-point size is the distance separating the two points composing an opposite point pair taken simultaneously on the extracted feature (see ISO 17450-3).

D.1.2 Default operator defining an opposite point pair

An opposite point pair can only be obtained on a linear feature of size.

Geometrically, opposite point pairs are obtained from the intersection of a non-ideal integral feature with an enabling feature which is a straight line.

If the intersection results in one point or more than two points, then at this location of the enabling feature, an opposite point pair cannot be defined. To define an opposite point pair, the intersection shall result in exactly two points.

By default (unless otherwise specified), a toleranced feature constituted by an opposite point pair, is obtained by applying the following sequences of operations:

- a) partition of the single feature from the non-ideal surface model or from the real surface of the workpiece;
- b) if the extracted feature does not contain an infinite number of surface points, reconstruction of the surface;
- c) filtration of the extracted feature defining the input feature.

A first enabling feature is established from a skeleton feature of the associated feature obtained from the input feature (the real integral feature) (see [Table D.1](#)). By default, the associated features are obtained by the total least squares criteria.

If the intersection between the input feature and the first enabling feature defines an opposite point pair, then a secondary enabling feature is not used (see [Table D.1](#)).

If a secondary enabling feature is to be used (see [Table D.1](#)), then the first enabling feature defines section lines. From these, each secondary enabling feature is established. The opposite point pairs are defined by the intersection between the section lines and the secondary enabling feature.

See examples in [Figures D.1](#) and [D.2](#).

Table D.1 — Enabling feature to construct the opposite point pairs

Type of associated feature	Skeleton feature related to the associated feature	Enabling feature	Secondary enabling feature required
Sphere	Point	Straight line goes through the point (Free orientation)	No
Cylinder	Straight line	Plane perpendicular to the skeleton line (Free location along the axis)	Yes, straight line
Torus	Circle		
Complex surface	Segment of a line		
Complex surface	Segment of a surface	Straight line perpendicular to the skeleton surface (Free location along the axis)	No
Two parallel planes	Plane	Straight line perpendicular to the skeleton (Stated orientation and free location)	No
Two coaxial cylinder	Cylinder		
Two equidistant complex surfaces	Complex surface		
Circle	Point	Straight line goes through the point (Free orientation)	No
Complex line	Segment of line		
Two parallel straight lines	Straight line	Straight line perpendicular to the skeleton line	No
Two equidistant complex lines	Complex line		

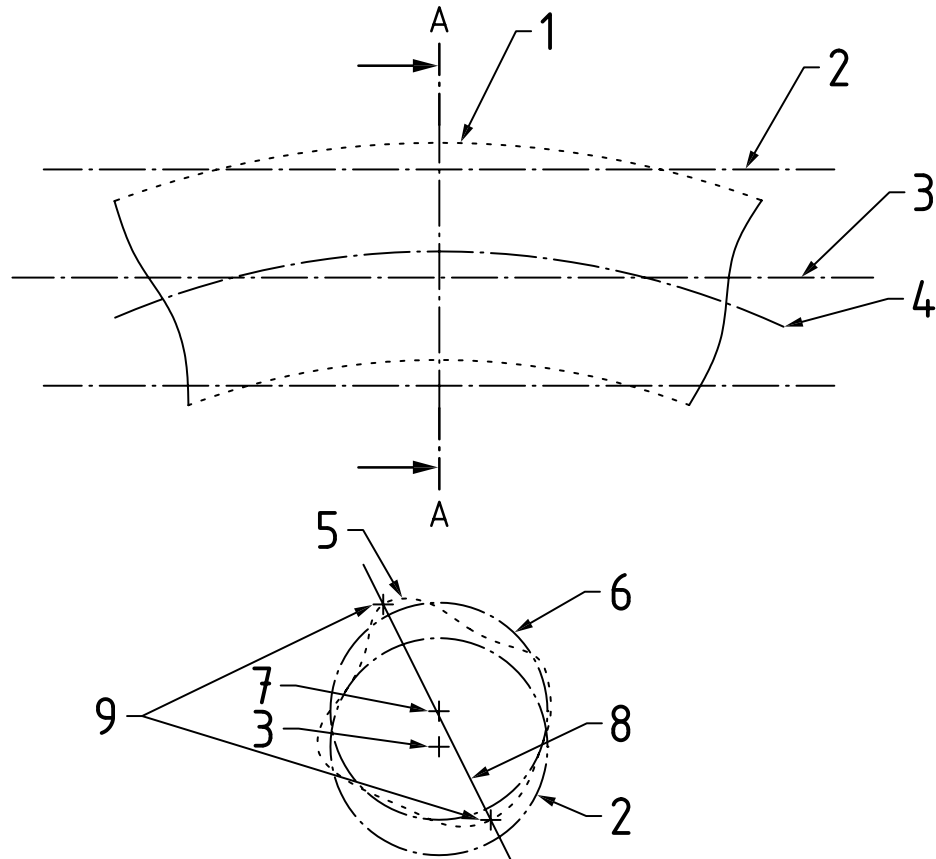

Key

- 1 extracted surface
- 2 associated cylinder
- 3 associated cylinder axis
- 4 extracted median line
- 5 extracted line
- 6 associated circle
- 7 associated centre
- 8 enabling feature, straight line going through 7, allowing the construction of an opposite point pair
- 9 opposite point pair

NOTE Section plane A-A is also an enabling feature.

Figure D.1 — Example of construction of an opposite point pair on a cylinder

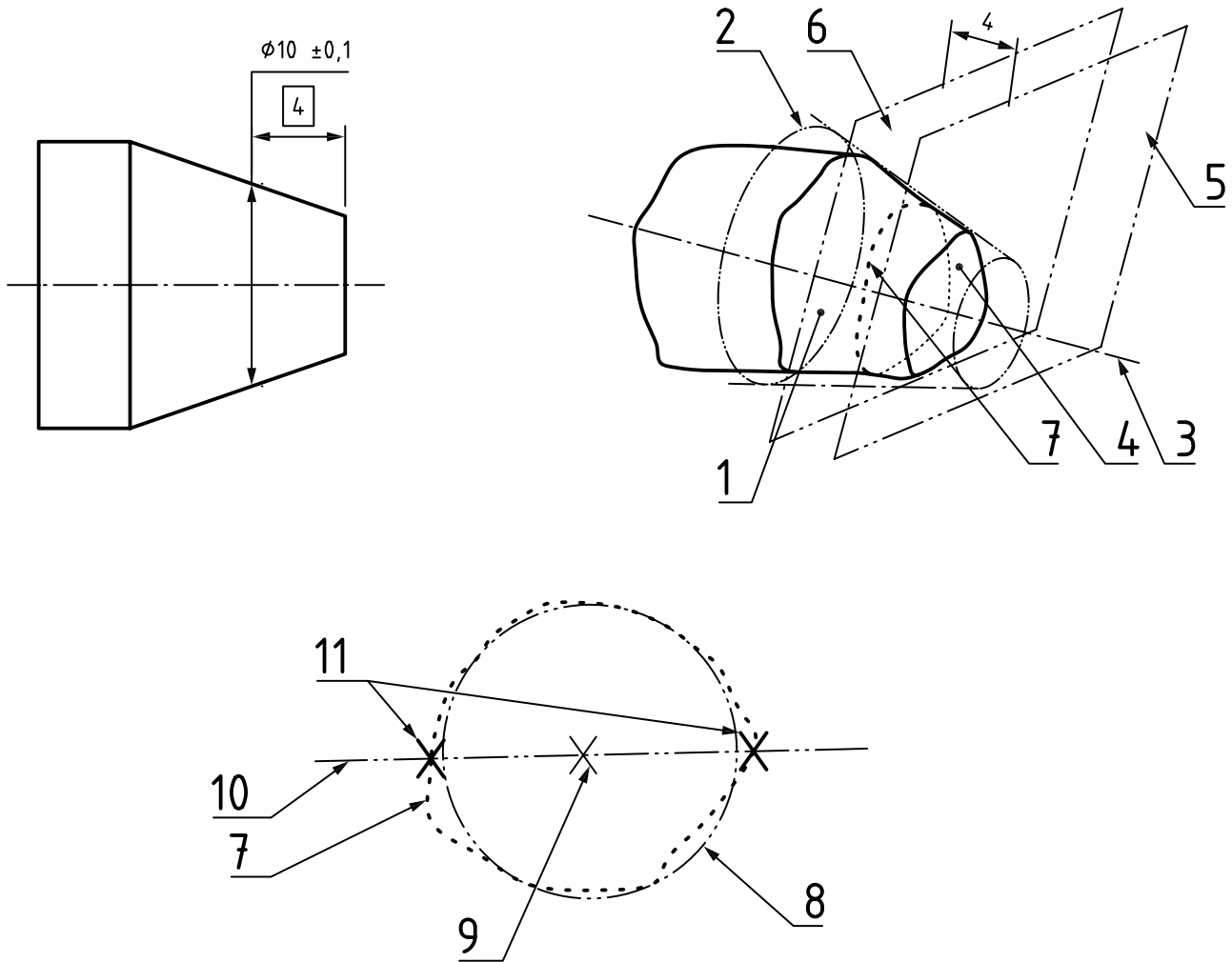

Key

- 1 complete extracted integral feature
- 2 associated integral feature
- 3 situation feature of the associated integral surface
- 4 real adjacent surface
- 5 associated plane with constraint external to the material and orientation constraint from the associated integral surface
- 6 intersection plane constructed parallel to 5 in the distance 4 mm
- 7 section line: extracted integral line
- 8 associated circle
- 9 centre of the associated circle
- 10 enabling feature, straight line going through 9, allowing the construction of an opposite point pair
- 11 opposite point pair

Figure D.2 — Example of construction of an opposite point pair built on a section line taken from a conical surface

D.2 Least squares size

Size of an associated feature is defined from the extracted feature with the total least squares criteria without material constraint, with size, orientation, and location considered as variable.

D.3 Minimax size

Size of an associated feature is defined from the extracted feature by minimizing the maximum value of local distances between the extracted feature and an associated feature to be optimized without material constraint, with size, orientation, and location variable.

Annex E (normative)

Graphical rules to locate and dimension the dimensional specification elements

[Annex E](#) presents the drawing rules for indication of size specifications.

The specification elements used as graphical indication shall be drawn in accordance with [Figures E.1](#) to [E.5](#) respecting distances between several indications on the drawing and between specification elements of one specification. The bottom reference line illustrated in [Figures E.1](#) to [E.5](#) can be the reference line of a dimensional specification or the upper line of a tolerance indicator indicating a geometrical specification.

The graphical distances are established from the width of the narrow line, identified by dn , defining the height of a character is equal to $10 dn$ (see also [Annex A](#)). The text line height is equal to $16 dn$.

When a text line of a dimensional specification is expressed without symbol, then the distance:

- the lower specification element and the reference line (or the tolerance indicator) (see [Figure E.1](#)), or
- the lower specification element of the upper text line and the upper specification element of the lower text line (see [Figure E.2](#))

shall be $2 dn$ apart [see [Figures E.1 a](#)) and [E.2 a](#))] or $0 dn$ apart [see [Figures E.1 b](#)) and [E.2 b](#))].

When a text line of a dimensional specification is expressed with symbol, the distance between

- the upper or lower specification element of a dimensional specification with symbol and another specification (dimensional or geometrical), or
- the upper specification element of a dimensional specification with symbol and the lower specification element of another dimensional specification with symbol

shall be (vertically) $2 dn$ apart (see [Figures E.3](#) to [E.5](#)).

When no (horizontal) space exists between two specification elements of a dimensional specification, a distance of $2 dn$ separates them.

A (horizontal) space exists only between the following (see [6.1.2](#)):

- the nominal value and the following specification element (see [Table 4](#), 1st, 2nd, and 4th lines);
- the upper or lower tolerance value and the following specification element (see [Table 4](#), 3rd line);
- “ nx ” indication and nominal value (see [Table 2](#), 7th line).

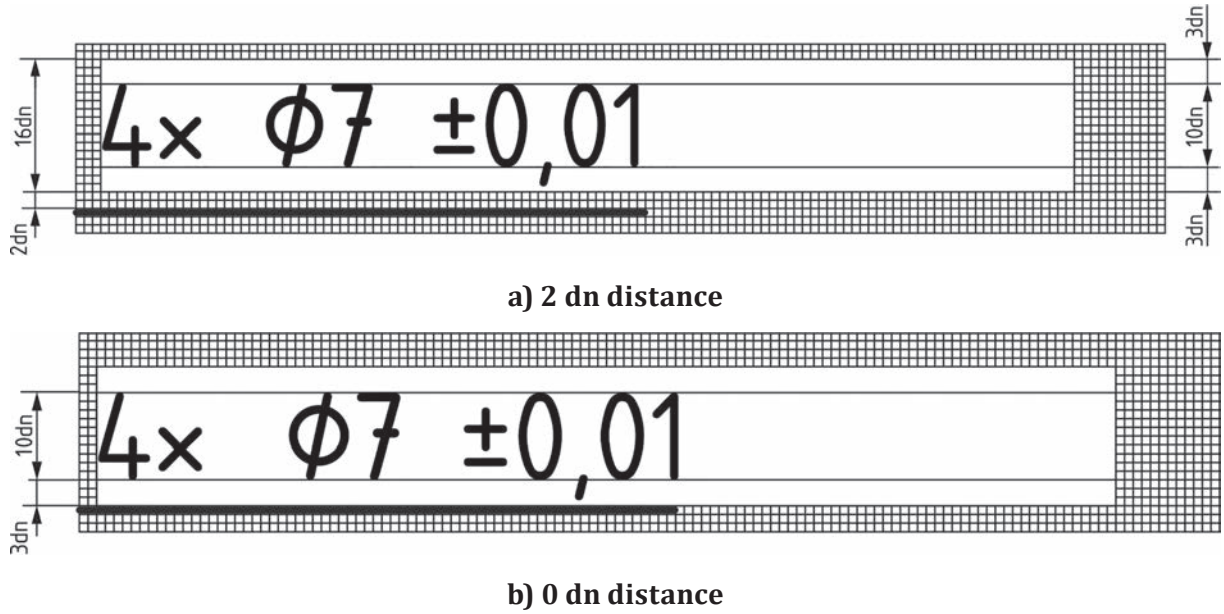

NOTE 1 a) has the same distance for dimensional specification with or without symbol.

NOTE 2 b) has the shorter distance for dimensional specification without symbol as distance for dimensional specification with symbol

Figure E.1 — Example of a dimensional specification indicated by one text line without symbol

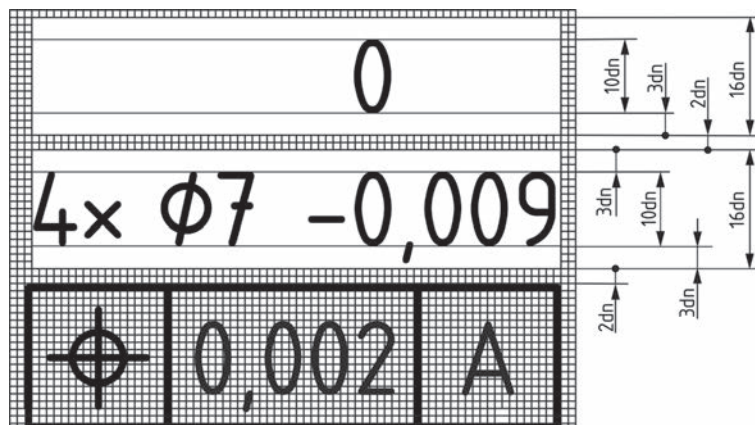

a) 2 dn distance

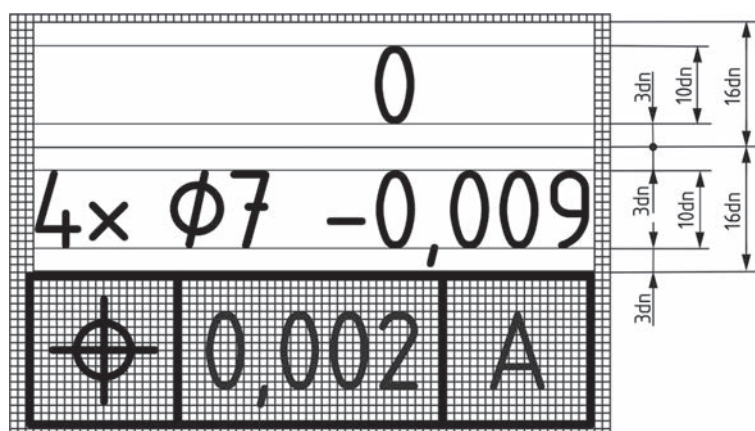

b) 0 dn distance

Figure E.2 — Example of a dimensional specification indicated by two text lines without symbol

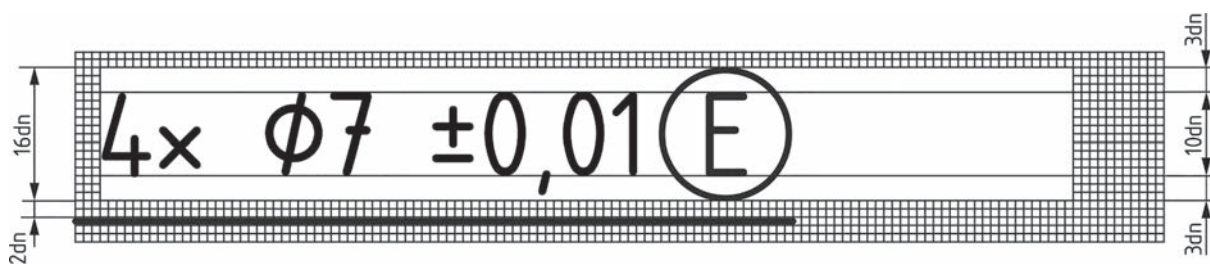

Figure E.3 — Example of a dimensional specification indicated by one text line with symbols

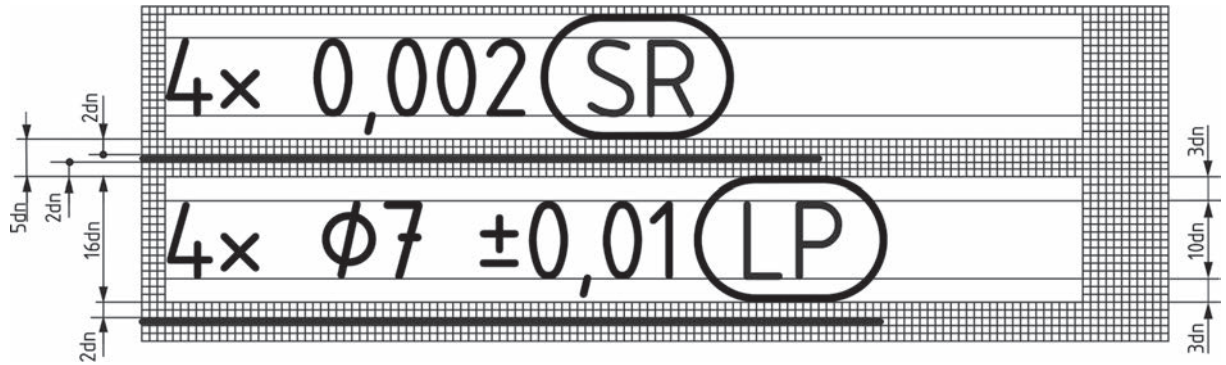

Figure E.4 — Example of two dimensional specifications indicated for each one by one text line with symbol

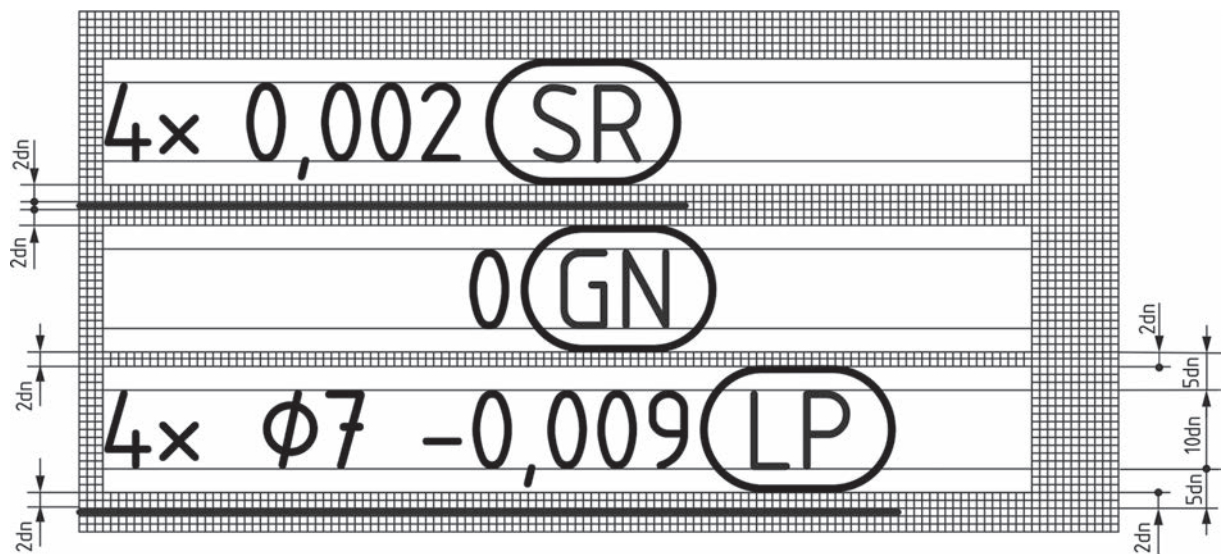

Figure E.5 — Example of two dimensional specifications indicated by one or two text lines with symbol

Annex F (informative)

Relation to the GPS matrix model

F.1 General

The ISO GPS matrix model given in ISO 14638 gives an overview of the ISO GPS system of which this part of ISO 14405 is a part.

The fundamental rules of ISO GPS given in ISO 8015 apply to this part of ISO 14405 and the default decision rules given in ISO 14253-1 apply to specifications made in accordance with this part of ISO 14405, unless otherwise indicated.

F.2 Information about this part of ISO 14405 and its use

This part of ISO 14405 establishes the default definition of size, special definitions, and drawing indications for sizes of linear feature of size, e.g. “cylinder” or “two opposite parallel planes”.

F.3 Position in the GPS matrix model

This part of ISO 14405 is a general ISO GPS standard which influences chain links A to C of the chains of standards on size in the GPS matrix model. The rules and principles given in this part of ISO 14405 apply to all segments of the ISO GPS matrix which are indicated with a filled dot (•).

Table F.1 — Position in the ISO GPS Standards matrix model

	Chain links						
	A	B	C	D	E	F	G
	Symbols and indications	Feature requirements	Feature properties	Conformance and non-conformance	Measurement	Measurement equipment	Calibration
Size	•	•	•				
Distance							
Form							
Orientation							
Location							
Run-out							
Profile surface texture							
Areal surface texture							
Surface imperfections							

F.4 Related International Standards

The related International Standards are those of the chains of standards indicated in [Table F.1](#).

Bibliography

- [1] ISO 492, *Rolling bearings — Radial bearings — Geometrical product specifications (GPS) and tolerance values*
- [2] ISO 1101, *Geometrical product specifications (GPS) — Geometrical tolerancing — Tolerances of form, orientation, location and run-out*
- [3] ISO 2768-1, *General tolerances — Part 1: Tolerances for linear and angular dimensions without individual tolerance indications*
- [4] ISO 3098-2, *Technical product documentation — Lettering — Part 2: Latin alphabet, numerals and marks*
- [5] ISO 10579:2010, *Geometrical product specifications (GPS) — Dimensioning and tolerancing — Non-rigid parts*
- [6] ISO 14638:2015, *Geometrical product specification (GPS) — Matrix model*
- [7] ISO/TS 17863, *Geometrical product specification (GPS) — Tolerancing of moveable assemblies*

